



RODLESS MECHANICAL CYLINDERS

BALL-SCREW DRIVEN

CMH

BELT DRIVEN

CMK

NIASA

WITH BALL-SCREW DRIVE, CMH

CMH: A rodless cylinder whose carriage is positioned by the movement of nuts attached to a ballscrew.

Each carriage is fitted with either a single ballscrew nut (M), or a trapezoidal nut (TR). The carriages are mounted on a prismatic linear bearing rail that is fitted inside an extruded aluminium body.

Where the loads exceed the rating of the standard units more than one carriage can be provided or additional external heavy duty bearing rails added. (HD)

These units translate rotary motion into a linear motion and can be incorporated into many types of machinery.

Note:

On page 14 we offer the same cylinder with toothed belt drive, ref. CMK

Where are the cylinders used? What are they used for?

- Where a linear force is required:
 - As a drive for feed mechanisms.
 - As a transport device.
 - As a head drive for industrial robots.
 - As a positioning drive for industrial robots.
- Where movements are required in one axis:
 - Positioning of materials on saws, presses, shears, etc.
 - Indexing of long parts for instance drilling of profiles etc.
 - As a drive for bearing mounted loads requiring a controlled speed.
- Where movements are required in two or more axes:
 - Parallel or crossed mounted table systems.
 - Three axis positioning systems.
 - Manipulators with numerical control.

TECHNICAL FEATURES

LENGTH L

CMH2 up to 6,000 mm.
CMH4 up to 6,000 mm.

THE LIMITS ARE IMPOSED BY:

- Length of ballscrew
- Speed of ballscrew
- Accuracy in longitudinal positioning
- Internal supports (see diagram SA).

ACCURACY

M	Accuracy of pitch 0,05/300 mm.	Accuracy of positioning $\pm 0,05$ mm
TR	Accuracy of pitch 0,20/300 mm.	Accuracy of positioning $\pm 0,20$ mm

Revolutions, speed, acceleration. Internal supports S.A.

	R.P.M. max.		Speed max.	Acceleration max.		Pitch Ballscrew	Diameter Ballscrew	Amount max.
	M	TR	(m/min)	M	TR	(mm)	(mm)	S.A.
CMH2	3.000	1.500	150	10	5	5,20,50	20	4
CMH4	3.000	1.500	120	10	5	5,10,20,40	32	4

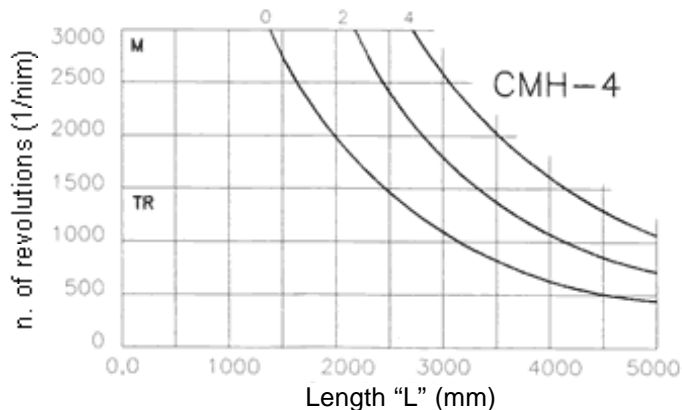
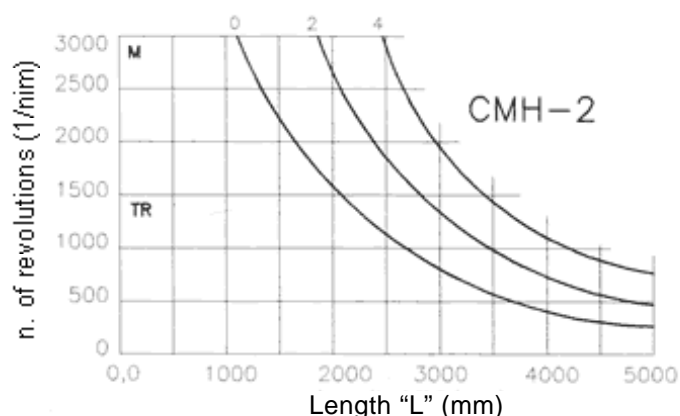

	Weight of cylinder Without stroke	Each 100mm. of stroke	Weight of carriage
CMH2	7 kg.	1,2 kg.	2,5 kg.
CMH4	16 kg.	1,8 kg.	6 kg.

MAINTENANCE, DEGREE OF PROTECTION

The cylinder is delivered greased and ready for operation.

1. Fixed bearing - free bearing - carriage
Original grease: Klüber ISOFLEX TOPAS. L152 - NLGI 2 DIN 51818.
Subsequent greasing every 400 - 500 hours of operation, with a lithium based bearing grease.

2. Profile sealing strip.
Original grease: Klüber POLYLUB LA 12 - NLGI 2 DIN 51818.
Subsequent greasing every 400 - 500 hours.

In the case of high speeds, NLGI 1 shall be used, and in the case of great stress NLGI 3.
The type of protection responds to VDE- IP44.

THECNICAL FEATURES

LOAD AND MOMENT CAPACITY MEASURED FROM THE CENTRE OF THE SHAFT OF THE CMH CYLINDER

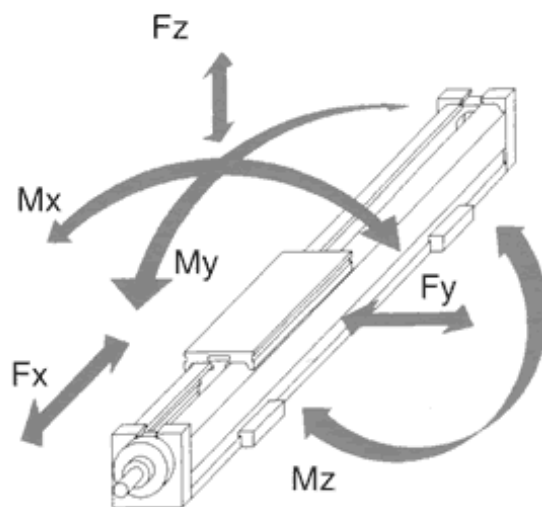

Size Type	CMH2			CMH4		
	000	1-HD	2-HD	000	1-HD	2-HD
Force (N)						
Fx (5,10)	2500	2500	2500	6000	6000	6000
Fx (20,40,TR,50)	1500	1500	1500	4000	4000	4000
Fy	500	750	950	1000	1500	2000
Fz	650	1200	1950	1300	2200	3200
Moment (Nm)						
Mx	250	500	750	500	1000	1400
My	700	1100	1500	1200	1800	2500
Mz	700	1100	1500	1200	1800	2500

000=Basic model
1-HD=with supplementary external guide
2-HD=with double supplementary external guide
Execution for heavy loads

DRIVE TORQUE AND EFFICIENCY LEVEL

$$Md = \frac{F_{total} \times P \times v}{2000 \times \eta \times \eta} \quad (\text{Nm})$$

F total = F action + Fa (N).
F action = Force resulting from all forces that the drive has to overcome
F action = Fx + (Fz x 0,2) (N).
Fa = Acceleration force (N).
Fa(N) = Fz (kg) x a (m / sec²)

P = Pitch in mm.
v = Safety factor > 1.
As standard between 2 and 3
= according to number of revolutions and type of nut.
Coarse pitches allow a higher efficiency

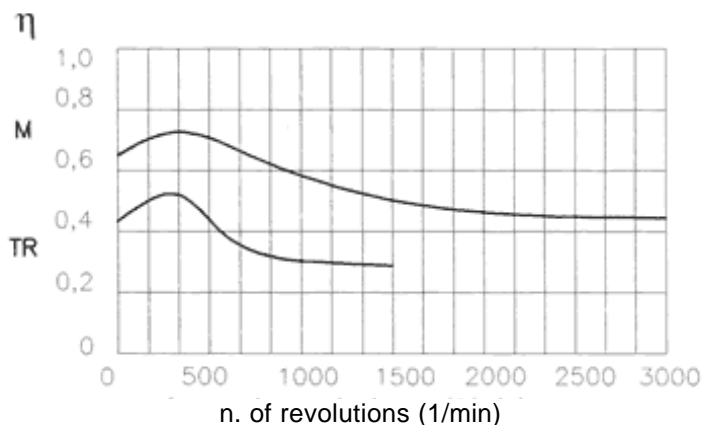

The torque required in the acceleration phase is:

$$M_a = \frac{m \times a \times P \times v}{2000 \times \eta} \quad (\text{Nm})$$

a = acceleration (m/sec²)

m = (mass of load) + (mass of carriage)(kg).

The **Total Moment** is then:

$$M_{\text{TOT}} = M_d + M_a$$

Torque table with no load at 150 and 1500 r.p.m.

(Average values without load)

The torque should not exceed 1,5 times the value given in the table for 150r.p.m. (in assembly)

		Inherent torque Md (Nm)				
		Execution	R.P.M.	M		
CMH2	Pitch			5	20	50
	000	150		0.50	0.59	1.80
		1500		0.82	0.99	2.80
CMH4	Pitch			10	40	
	000	150		4.40	5.80	
		1500		6.40	8.50	

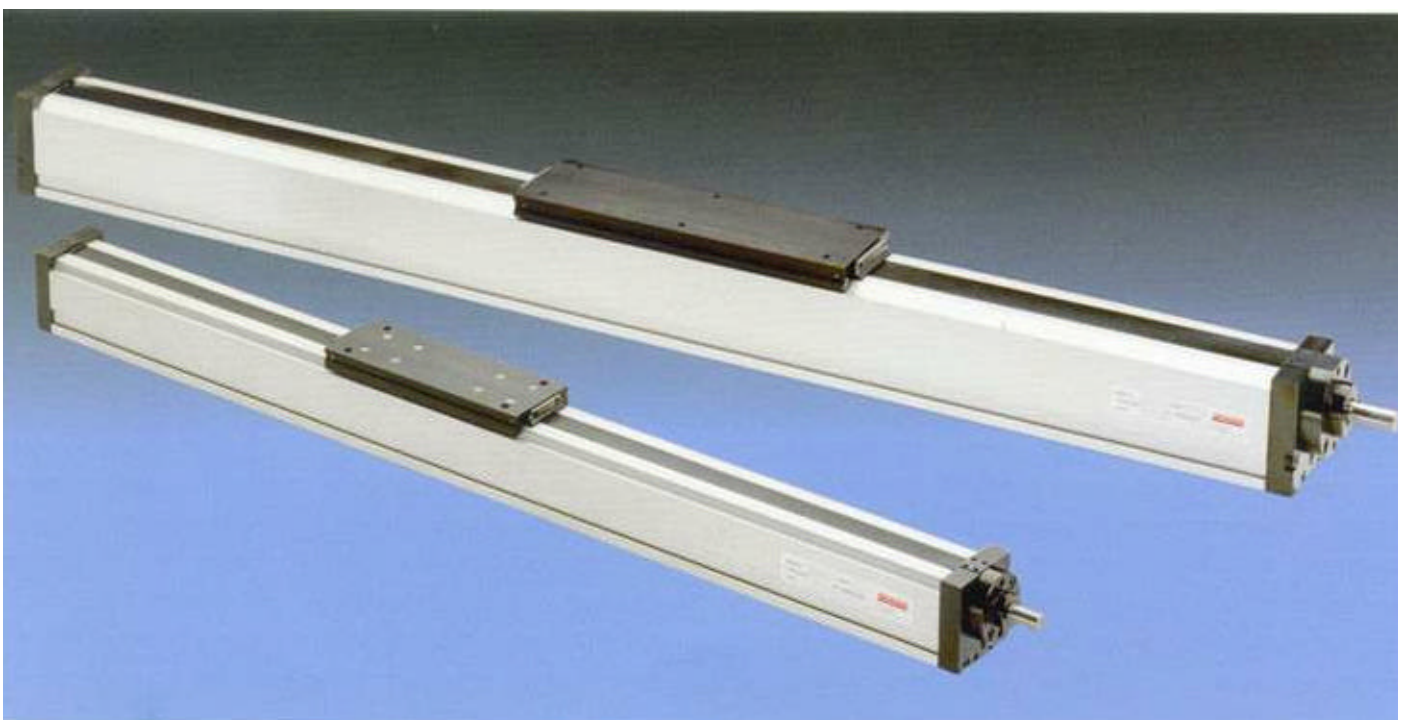

MU FIXING STRIP (4 Per cylinder without load)

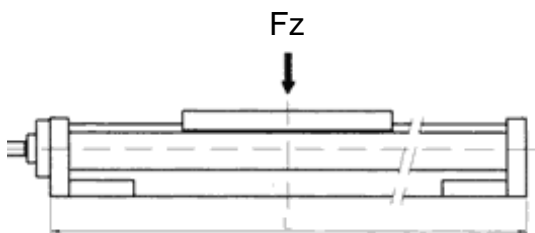
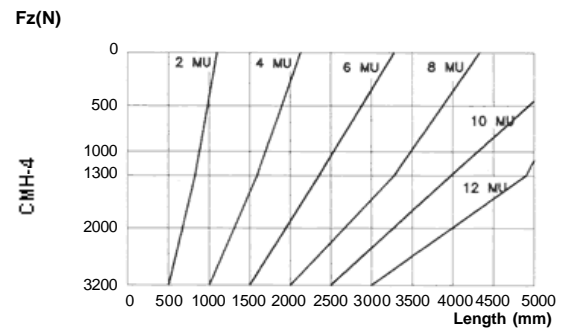
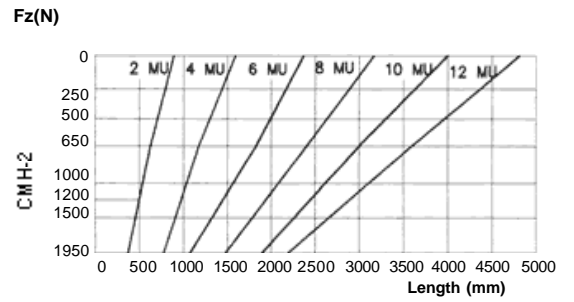
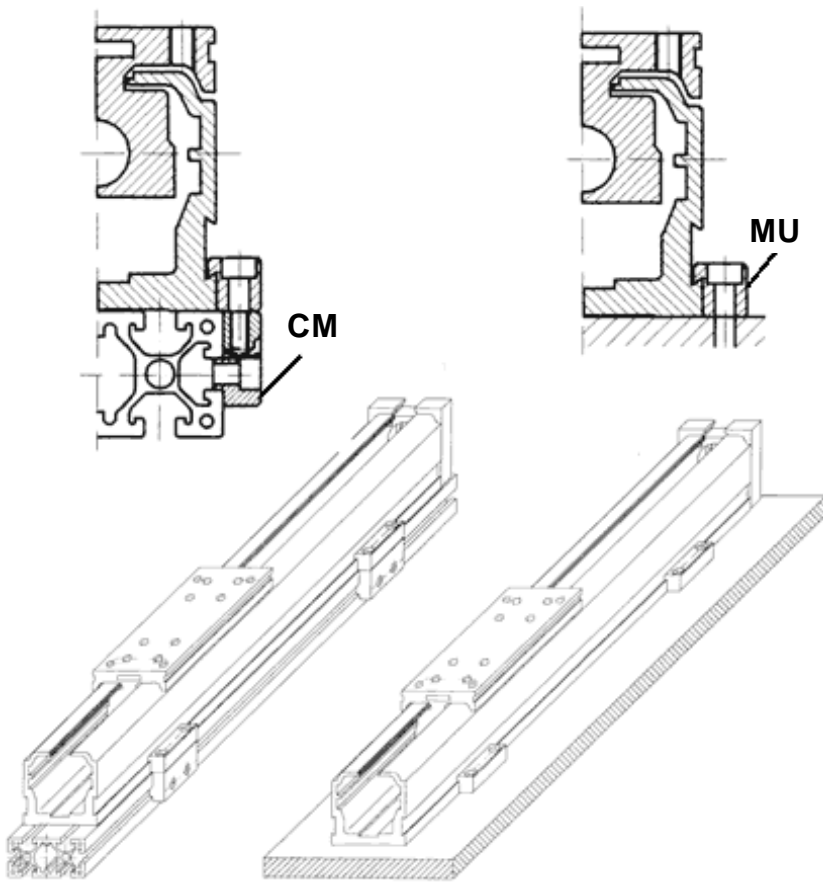

INPUT POWER FROM TORQUE AND SPEED

$$Pa = \frac{M \text{ total} \times n}{9550} \text{ (kW)}$$

M total = Nm

n = R.P.M.

Pa = Power required

speed (rpm)	500	1000	1500	2000	2500	3000	
		TR			M		
	Input power (kW)						
(Nm)							
0	0	0	0	0	0	0	
0,5	0,03	0,06	0,08	0,11	0,14	0,16	
1	0,06	0,11	0,16	0,21	0,27	0,32	
1,5	0,09	0,16	0,24	0,32	0,40	0,48	
2	0,11	0,21	0,32	0,42	0,53	0,63	
2,5	0,14	0,27	0,40	0,53	0,67	0,79	
3	0,16	0,32	0,48	0,63	0,80	0,95	
3,5	0,19	0,37	0,56	0,74	0,93	1,11	
4	0,21	0,42	0,63	0,84	1,05	1,26	
4,5	0,24	0,47	0,72	0,95	1,19	1,42	
5	0,27	0,53	0,80	1,05	1,32	1,58	
5,5	0,30	0,58	0,88	1,16	1,45	1,74	
6	0,32	0,63	0,95	1,26	1,58	1,98	
7	0,37	0,74	1,11	1,47	1,84	2,21	
8	0,42	0,84	1,26	1,68	2,10	2,52	
9	0,47	0,95	1,42	1,89	2,37	2,84	
10	0,53	1,05	1,58	2,10	2,63	3,14	
12,5	0,67	1,32	1,98	2,63	3,29	3,94	
15	0,80	1,58	2,37	3,15	3,94		
17,5	0,95	1,84	2,76	3,68			
20	1,05	2,10	3,15				
25	1,32	2,63	3,94				
30	1,58	3,15					
35	1,84	3,68					
40	2,1						
45	2,37						
50	2,63						

M000 BASIC MODEL

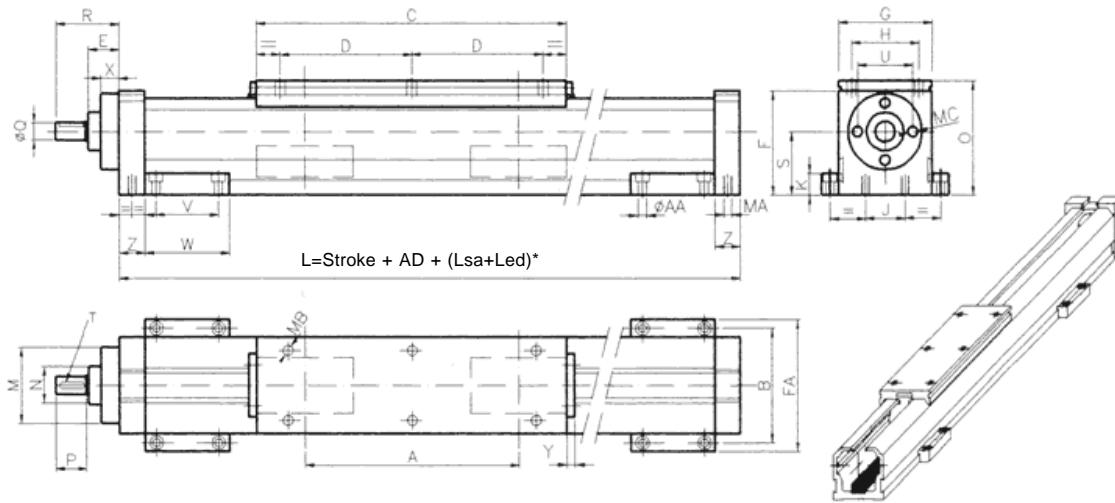

DIMENSIONS

	Lsa	A	B	C	D	E	F	G	H	J	K	M	N	O	P	
Model	0 2 4															
CMH-2	0 50 100	160	90	250	100	25	82	76	55	32	17	60	30 h6	90	25	
CMH4	0 90 180	260	120	350	150	33	110	106	75	75	17	90	50 h6	125 ⁺⁰ _{-0,5}	40	
	Q	R	S	T	U	V	W	X	Y	Z	AA	AD	MA	MB	MC	FA
Model																
CMH2	14 h6	52	50	5x20x3	45	50	68	15	10	20	7	320	M6x15	M8x12	M8x15	104
CMH4	20 h6	75	69,5	6x35x3,5	72	50	68	20	10	25	7	420	M10x20	M8x17	M8x20	134

M400 CYLINDER FOR HEAVY LOADS

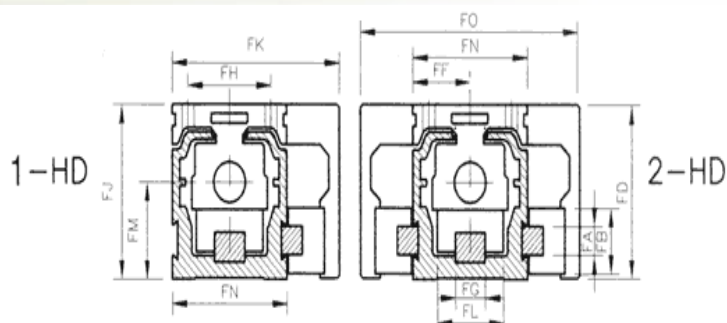

DIMENSIONS

Model	FA	FB	FD	FF	FG	FH	FJ	FK	FL	FM	FN
CMH2_1-HD	15	34	89,5	38	20	55	90	110,5	44	50,5	76
CMH4_1-HD	15	34	124,5	53	23	75	125 ⁺⁰ _{-0,5}	140,5	48	73	106
Model	FA	FB	FD	FF	FG	FH	FJ	FL	FM	FN	FO
CMH2_2-HD	15	34	89,5	38	20	55	90 ₊₀	44	50,5	76	145
CMH4_2-HD	15	34	124,5	53	23	75	125-0,5	48	73	106	175

*L_{SA}: Internal supports (when the length requires it)
L_{ED}: Safety distance for switches, etc.

M600
TWO AXIS CONFIGURATION
X-Z EXECUTION

Model	A	B	C
CMH-2	100	125,5	9,5
CMH-4	160	160,5	15

Model	D	L
CMH-2	15	250x250
CMH-4	20	350x350

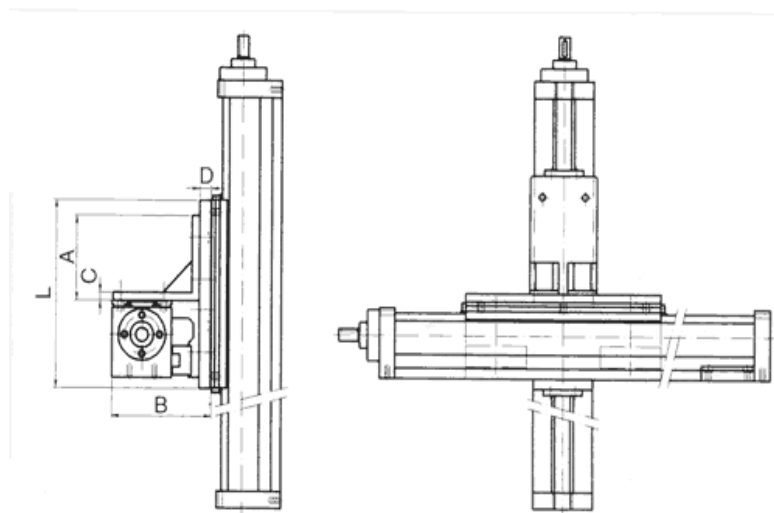

M610
CYLINDER WITH SEPARATE
ADDITIONAL CARRIAGE OR
WITH RIGHT-LEFT THREAD

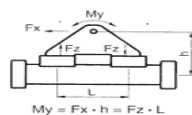

Model	Lsa			AD
	0	2	4	
CMH2	0	50	100	320
CMH4	0	90	180	420

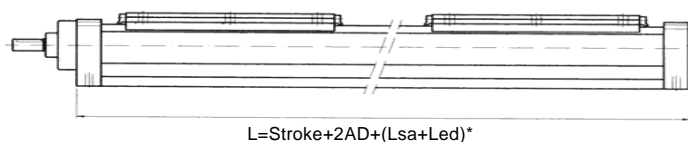

*Lsa: Internal supports (when the length requires it)
Led: Safety distance for switches, etc.

M620
TWO CYLINDERS WITH
A PARALLEL BELT DRIVE

Model	A	B	C
CMH2	30	60	80
CMH4	37	70	100

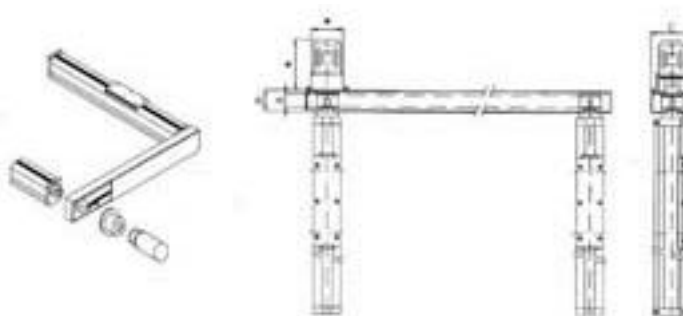

*Dependant on the motor

**M810
CYLINDER WITH RIGHT ANGLED**

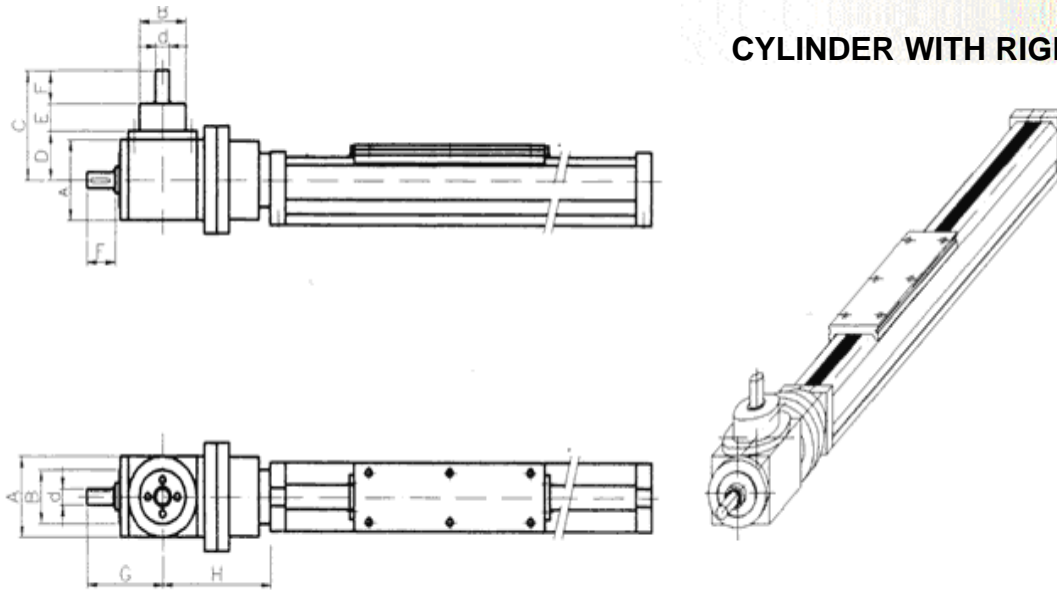

Model	A	B	C	D	E	F	G	H	d	Right angled
CMH2	90	60	122	55	30	35	98	123	18	VH1
CMH4	90	60	122	55	30	35	98	146	18	VH1

**M820
CYLINDER WITH RIGHT
ANGLED BELT DRIVE**

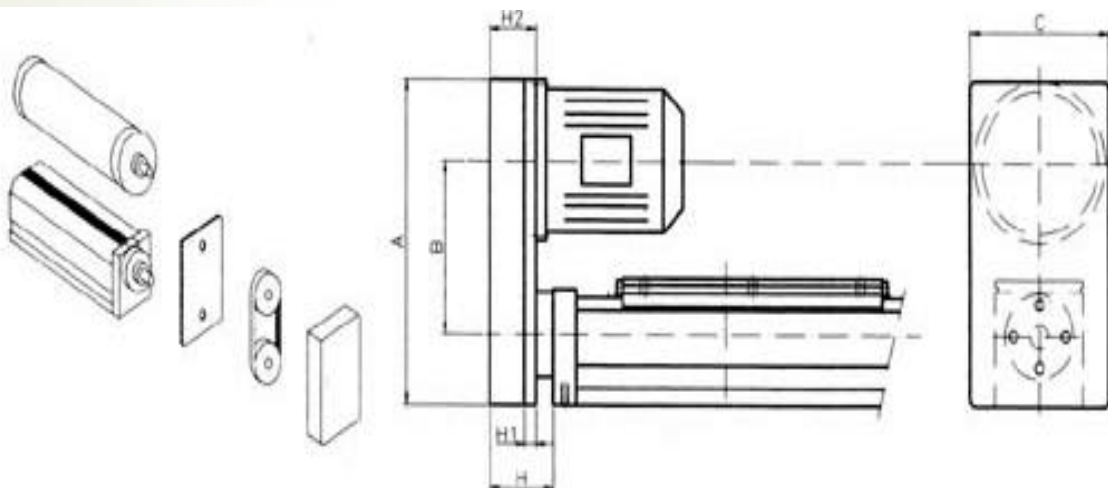

Model	A	B	C	H	H1	H2
CMH2	295	145	150	85	20	70
CMH4	320	160	180	100	25	80

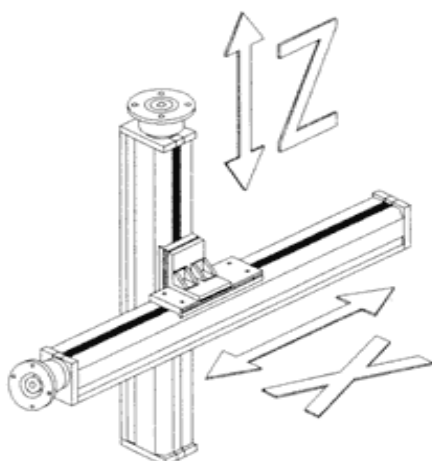

M600
TWO AXIS EXECUTION

M630
TWO AXIS EXECUTION
WITH DOUBLE "X" AXIS

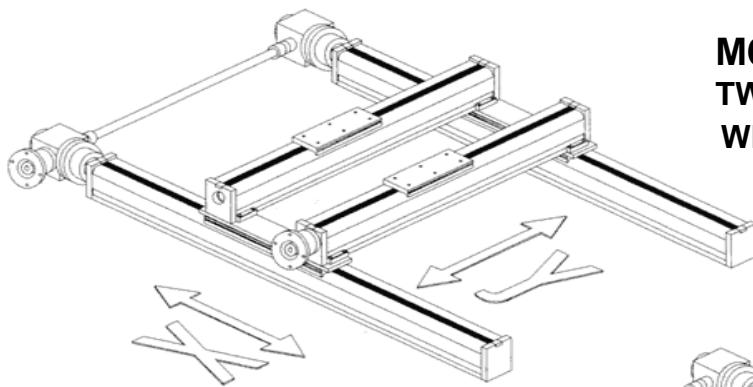
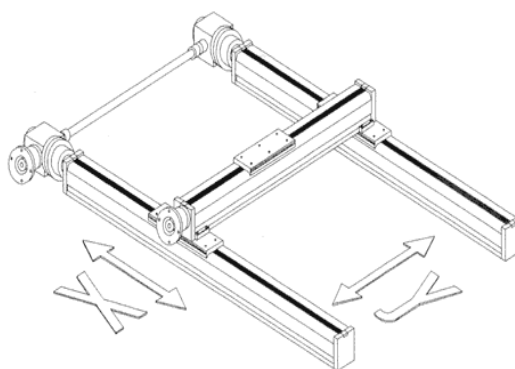

M640
TWO AXIS EXECUTION
WITH DOUBLE "X-Y" AXES

M650
THREE AXIS EXECUTION

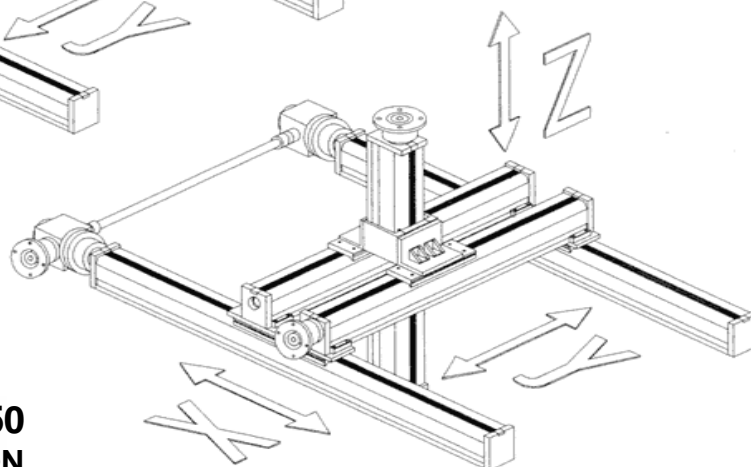

**EXAMPLE OF ORDER CODE
OF A BALLSCREW MOVED UNIT:**

Ballscrew cylindrer, size 2, rolled ballscrew pitch 5, stroke of 2000 mm, with 2 internal supports, with 6 fixing strips and total length of 2320 mm.

	CMH	2	KGT	5	2000	2 SA	6 MU	2320
Cylinder model								
Size 2/4								
Type of srew	Ballscrew=KGT Trapezoidal screw= TR							
Srew pitch (mm)	KGT:CMH-2 5/20/50 CMH-4 5/10/20/40 TR: 5							
Stroke (mm)								
Internal supports SA	0 / 2 / 4							
MU :No. of fixing strips (4 units supplied as standard)								
Total length (mm)								

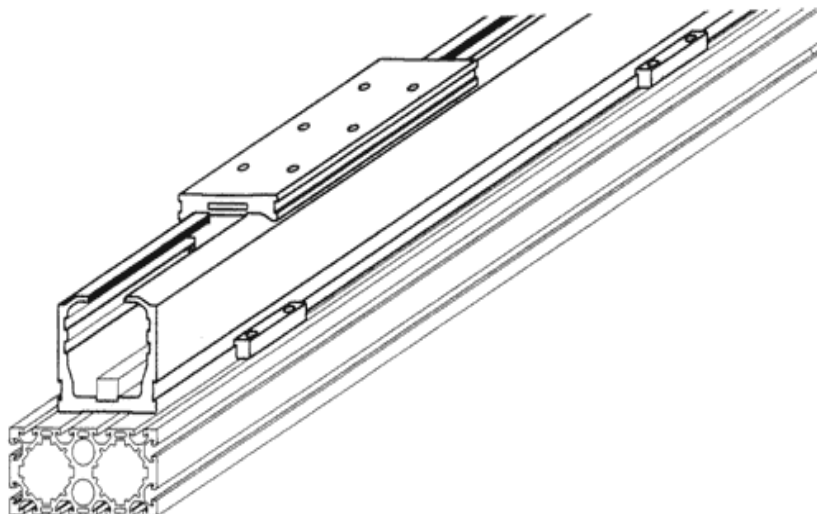

WITH A TOOTHED BELT DRIVE, **CMK**

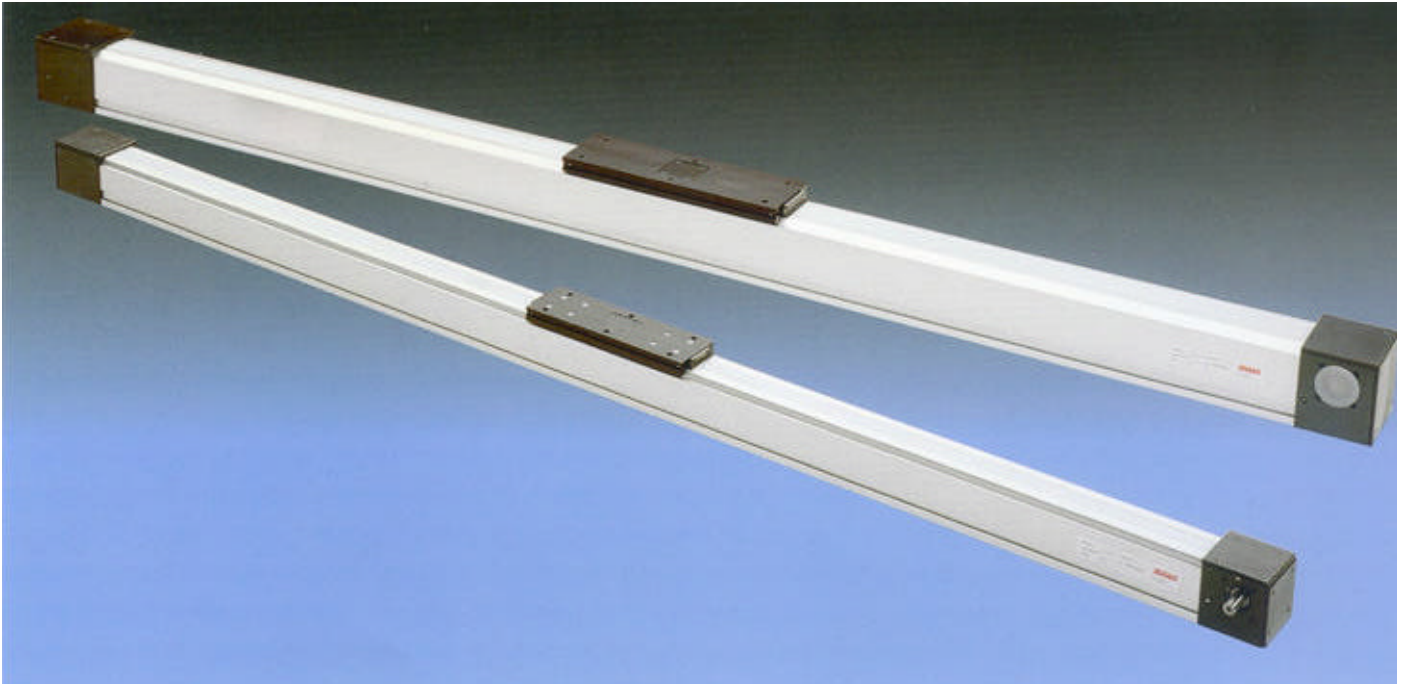

Linear actuators, or rodless mechanical cylinders, with movement achieved using a ballscrew, were developed by Neff 20 years ago and have been granted numerous international patents and awards.

We can now offer an alternative rodless cylinder in which the carriage is mounted on a linear bearing that is driven via a steel braided toothed belt. This enables speeds of up to 5 m/s a second to be reached.

With the fast CMK cylinders, we can move the carriage at the speed of a pneumatic cylinder but with the advantage of an

infinite number of intermediate stops and total control of movement and positioning speeds.

This model, although less accurate than a ballscrews, provides the market with an economical solution when a repeatability of 0.3 mm or greater is required.

For instance stops for saws, shears, palletisers, painting equipment and numerous other applications where positional accuracy is not critical.

MECHANICAL RODLESS CYLINDERS

TECHNICAL FEATURES OF THE CMK CYLINDER

LENGTH L CMK-3, CMK-5 up to 7.000 mm

REPEATABILITY CMK-3, CMK-5 up to 0,3 mm

	v. max	a.max	Feed per revolution	Diameter of pulley	Type of belt	stroke 0	Weights	
	m/sg	m/sg ²	mm	mm		kg	each 100mm	carriage
							kg	kg
CMK-3	3	20	120	38,20	23-ATL-5	7,5	1	2
CMK-5	5	20	200	63,66	40-ATL-10	17	1,4	5,5

MAINTENANCE AND LUBRICATION

The CMK requires similar lubrication to ball bearings. Lubrication using grease is always preferable. Under normal working conditions, the greasing period should not be more then 200 hours of operation.

Original greasing : Klüber ISOFLEX TOPAS. L152 – DIN 51818

LOADS AND MOMENTS

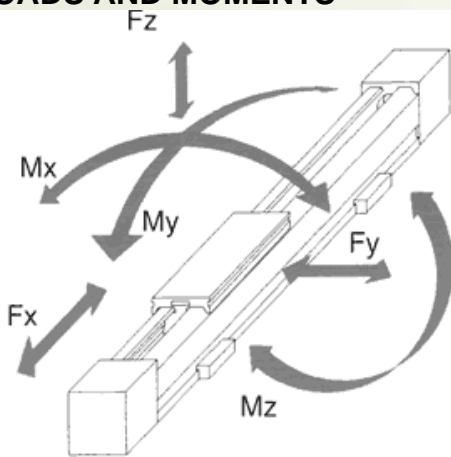

Size Model	CMK-3			CMK-5		
	BASE	1-HD	2-HD	BASE	1-HD	2-HD
Force [N]						
Fx	820	820	820	3000	3000	3000
Fy	500	750	950	1000	1500	2000
Fz	650	1200	1950	1300	2200	3200
Moment [Nm]						
Mx	250	500	700	500	1000	1400
My	700	1100	1500	1200	1800	2500
Mz	700	1100	1500	1200	1800	2500

IDLE TORQUE (Nm)

	CMK-3	CMK-5
At 150 rpm	1,2	6,8
At 500 rpm	2,5	8,2
At 1500 rpm	3,2	10,5

FORCE/SPEED DIAGRAM

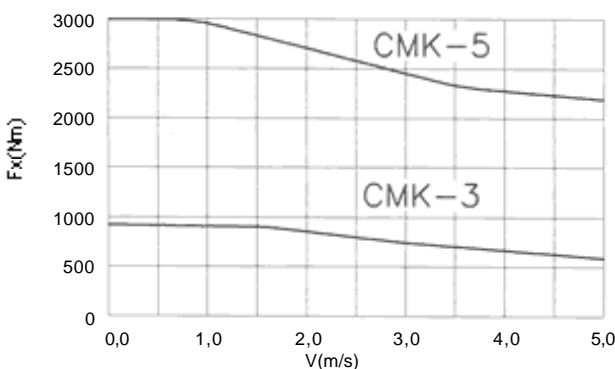

SPEED/ACCELERATION DIAGRAM

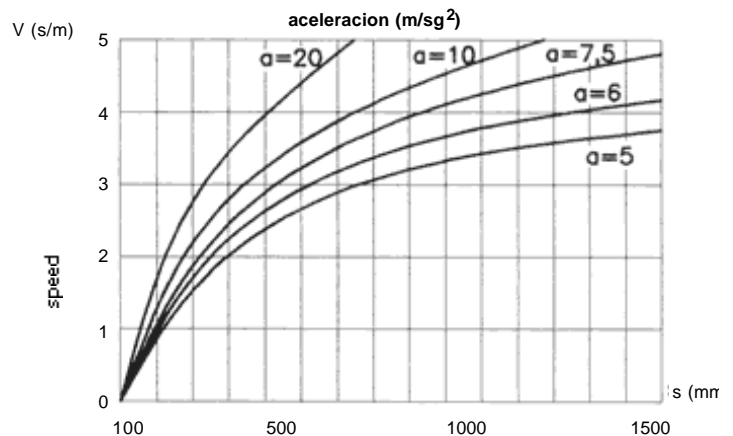

BASIC MODEL M000

BASIC MODEL

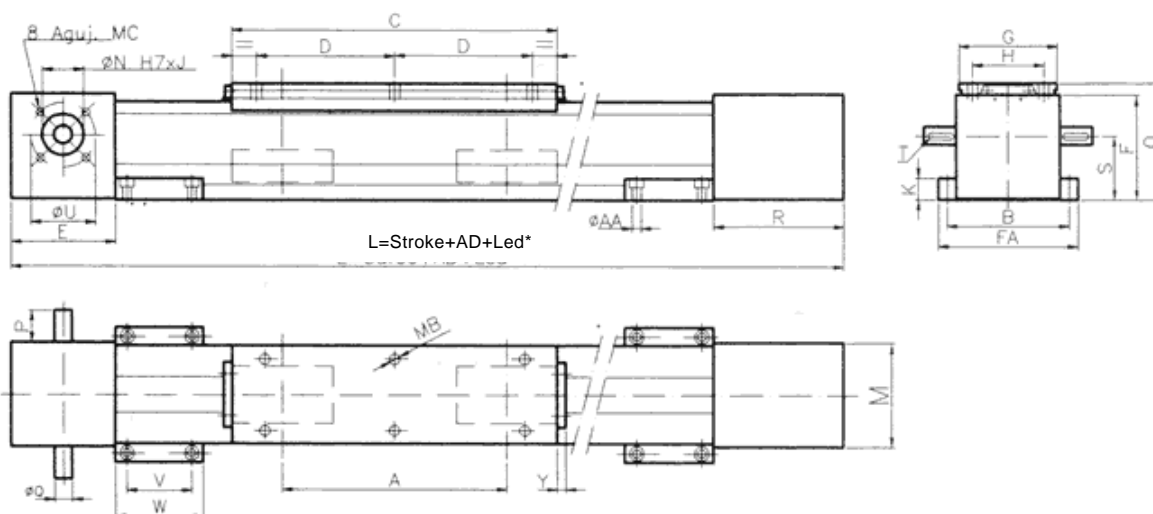

DIMENSIONS

Model	A	B	C	D	E	F	G	H	J	K	M	N	O	P	Q	R
CMK-3	160	90	250	100	80	84	76	55	3,5	17	80	32	90	25	14	h6 100
CMK-5	260	120	350	150	100	113	106	75	8	17	115	47	125 ⁺⁰ _{-0,5}	35	18	h6 120

Model	S	T	U	V	W	Y	AA	AD	MB	MC	FA	Belt pitch	Nº of teeth	Feed pitch
CMK-3	5,5	5x20x3	50	50	68	10	7	450	M8x12	M8x15	104	5	24	120
CMK-5	72,5	6x30x3,5	60	50	68	10	7	600	M8x17	M8x20	134	10	20	200

M400

CYLINDERS FOR HEAVY LOADS

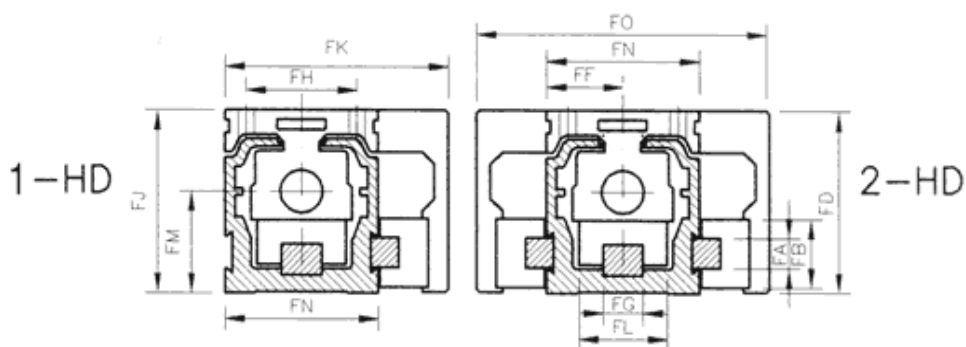

DIMENSIONS

Model	FA	FB	FD	FF	FG	FH	FJ	FK	FL	FM	FN
CMK-3_1-HD	15	34	89,5	38	20	55	90	110,5	44	50,5	76
CMK-5_1-HD	15	34	124,5	53	23	75	125 ⁺⁰ _{-0,5}	140,5	48	72,5	106

Model	FA	FB	FD	FF	FG	FH	FJ	FL	FM	FN	FO
CMK-3_2-HD	15	34	89,5	38	20	55	90	44	50,5	76	145
CMK-5_2-HD	15	34	124,5	53	23	75	125 ⁺⁰ _{-0,5}	48	72,5	106	175

*Led = Safety distace for switches, etc.

**EXAMPLE OF ORDER CODE
OF A BELT DRIVEN UNIT:**

Belt cylinder, size 3, pitch 120 belt driven unit, stroke of 1000 mm, with 4 fixing strips and total length of 1450 mm.

	CMK	3	120	1000	4 MU	1450
Belt cylinder						
Size 3 / 5						
Feed per revolution 120 / 200						
Stroke (mm)						
MU: No. of fixing strips (4 units are supplied as standard)						
Total length (mm)						

EXAMPLES

**MOUNTING OF TWO CYLINDERS
IN PARALLEL PROVIDING
A LIFT MECHANISM**

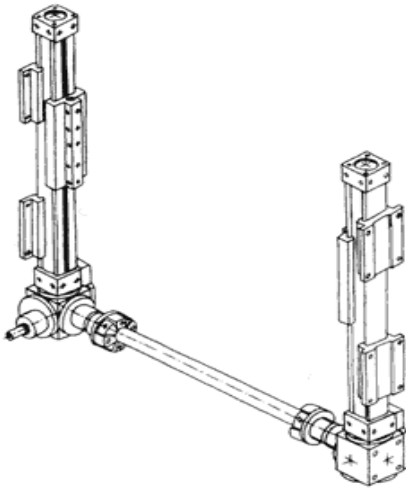

**PARALLEL CYLINDERS
FOR SIMULTANEOUS
MOVEMENT**



**TWO AXIS
ARRANGEMENT**

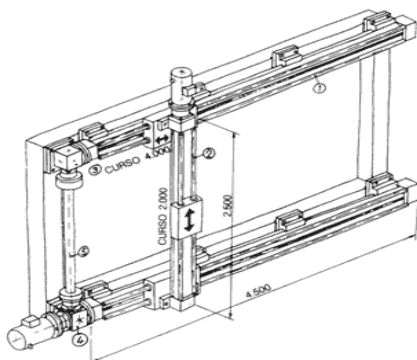

**THREE AXIS
ARRANGEMENT**

