



TAWI



User manual and spare part list for CR80 (ENG)



Declaration of Conformity

According to 2006/42/EG Annex IIA

This manual and the Declaration of conformity is only valid when using TAWI authorised tools.

Manufacturer

TAWI AB

Box 10205, Transportgatan 1, 434 23 Kungälv, Sweden

Authorised representative

Name:

Company:

Address:

Machine description

Product group:

TAWI Lifting Trolleys

Product type:

CR80

Serial number:

It is hereby confirmed that the machine mentioned is in compliance with the following directives:

- 2006/42/EG Machine Directive
- 2014/30/EU EMC Directive

The following harmonised standards have been used:

- 12100:2010 Safety of machinery - General principles for design - Risk assessment and risk reduction
- SS-EN 349+A1:2008 Safety of machinery - Minimum gaps to avoid crushing of parts of the human body
- SS-ISO 22915-16:2015 Industrial trucks - Verification of stability - Part 16: Pedestrian-propelled trucks
- SS-EN ISO 3691-5:2015 Industrial trucks. Safety requirements and verification. Part 5: Pedestrian-propelled trucks
- SS-EN 12895:2015 Industrial trucks - Electromagnetic compatibility
- SS-EN 1175-1+A1:2010 Safety of industrial trucks - Electrical requirements - Part 1: General requirements for battery powered trucks
- SS-EN ISO 13849-1:2008 Safety of machinery - Safety-related parts of control systems - Part 1: General principles for design
- SS-EN 60204-1 Safety of machinery – Electrical equipment of machines – Part 1: General requirements

Notified body:

Inspecta

Date:

Place:

Kungälv, SWEDEN

Signature:

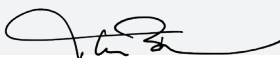

Thomas Bräutigam, CEO TAWI Holding

Signature:



David Ranfalk, Responsible for the technical dossier

CE

Declaration of Incorporation of Partly Completed Machinery

According to 2006/42/EG Annex IIB

A final certification is required before sending the lifter to an end customer.



Important

When receiving a Declaration of Incorporation of Partly Completed Machinery according to 2006/42/EG Annex IIB, a final certification according to 2006/42/EG Annex IIA is required before the lifter can be sent to an end customer.

The main part of this is to make sure that the lifter complies to *SS-ISO 22915-16:2015 Industrial trucks - Verification of stability - Part 16: Pedestrian-propelled trucks* and to perform a risk analysis.

Manufacturer

TAWI AB, Box 10205, Transportgatan 1, 434 23 Kungsbacka, Sweden

Authorised representative

Name:

Company:

Address:

Machine description

Product group:

TAWI Lifting Trolleys

Product type:

CR80

Serial number:

It is hereby confirmed that the machine mentioned is in compliance with the following directives:

- 2006/42/EG Machine Directive
- 2014/30/EU EMC Directive

The following harmonised standards have been used:

- 12100:2010 Safety of machinery - General principles for design - Risk assessment and risk reduction
- SS-EN 349+A1:2008 Safety of machinery - Minimum gaps to avoid crushing of parts of the human body
- SS-EN ISO 3691-5:2015 Industrial trucks. Safety requirements and verification. Part 5: Pedestrian-propelled trucks
- SS-EN 12895:2015 Industrial trucks - Electromagnetic compatibility
- SS-EN 1175-1+A1:2010 Safety of industrial trucks - Electrical requirements - Part 1: General requirements for battery powered trucks
- SS-EN ISO13849-1:2008 Safety of machinery - Safety-related parts of control systems - Part 1: General principles for design
- SS-EN 60204-1 Safety of machinery – Electrical equipment of machines – Part 1: General requirements

Notified body:

Inspecta

Date:

Place:

Kungsbacka, SWEDEN

Signature:

Thomas Bräutigam, CEO TAWI Holding

Signature:

David Ranfalk, Responsible for the technical dossier

CE



Contents

1	Safety & important information	05
	WEEE, RoHS and REACH	08
	Do not make modifications	08
	Markings and labels on the CR80	08
2	Warranty	11
3	Overview	12
	Loading	14
4	Quick start	15
	Fasten tools on the sleigh	15
	Torques to apply	15
5	User instructions	16
	Start the lifter	16
	Charge the battery	16
	Battery charging indicator	18
	Move the lifter	18
	Apply brakes to the lifter	18
	Operating tools	19
6	Service & maintenance	23
	Inspections	23
	Torques	24
7	Troubleshoot	26
	Main unit	26
8	Tools and accessories	28





1 Safety & important information

This chapter presents safety information about the TAWI CR80. Some of the information is divided in Warning, Caution and Important. This division is based on the severity of the consequences that may occur if the instructions are not followed. Stickers and labels are explained in this chapter and information is provided about directives that TAWI follows.

This manual and the Declaration of conformity is only valid when using TAWI authorised tools.



WARNING: Risk of personal injuries or major material damages.



Caution: Risk of material damages.



Important: Important information is highlighted.





WARNING

- Before operating a lifter, this manual must be read and understood.
- Always apply brakes to the rear wheels when loading and unloading.
- NEVER exceed the indicated max load capacity on the lifter or on a tool. If a special tool is used, there might be a separate max load capacity indicated on the tool, make sure to always comply to both.
- Make sure to load according to the load diagrams including y-distances. See *Labels on TAWI CR80 on page 09* and *Loading on page 14*.
- Make sure loads are distributed evenly on the platform and always load according to load diagram.
- The operator's position should always be behind the lifter when it is used, also when using the hand control!
- Stay clear of the area underneath a tool at all times.
- Stay clear of moving parts.
- During all service and maintenance, lay the lifter down on the floor (on its back).
- In order to deal with the lifter's cables and wiring, a good knowledge of electricity and TAWI electrical schedules of the lifters is required. Faults can cause damage to people and property.
- NEVER climb on the lifter.
- NEVER stand on the housing or any other part of the lifter.



Caution

- The lifters are made for indoor use on a smooth, even floor/surface. Max allowed inclination is 4%.
- The recommended temperature range for the lifters is 10 - 50 degrees Celsius (50 - 122 degrees Fahrenheit). The lifting performance may vary when the temperature deviates from 20 degrees Celsius (68 degrees Fahrenheit).
- Make sure there is good lighting in areas where the lifter is operated.
- Use caution when passing over thresholds, floor drains, hoses or cables.
- Lifter can be washed with pressure washers. The CR80 have IP65 rating.
- Recharge the battery in a designated dry area.
- Any part of this lifter or accessories that show signs of wear or other damage must be replaced immediately. The lifter must not be used before the damaged part is replaced.
- Do not use the lifter while it is plugged into an outlet.
- Only run the lifter when it is completely assembled.
- Wear steel toe shoes with good grip when operating the lifter.
- Never manually move the tool past the top switch.
- There is always one top switch and one bottom switch assembled on the lifter. NEVER move the top or bottom switches.





Important

- To prevent damages and injuries caused by improper use and not to compromise the warranty and liability: Follow the instructions in this manual at all times!
- The lifter is certified as a unit together with a specific tool. If the tool is changed, this must be checked with TAWI. If a tool is used that is not authorised by TAWI, a new final certification of the complete lifter must be implemented.
- Use the ^{TAWI} CR80 or accessories only in accordance with all instructions in this manual.
- Keep this manual accessible to all staff.
- The lifter is not intended for use by persons (including children) with reduced physical, sensory or mental capabilities, or lack of experience or knowledge, unless they have been given supervision or instruction concerning use of the appliance by a person responsible for their safety. Children should be supervised to ensure that they do not play with the lifter.
- Due to a safety mechanism, if a tool hits an object or surface when lowered, it will stop immediately.
- Use only TAWI original spare parts.
- Always follow any local/national recommendations as well as the instructions in this manual.
- The lifter and accessories should only be used when they are in perfect working order.
- If the lifter is to be out of use for a longer period, ensure that the battery is maintained (not drained).
- Intermittent-duty:15%.
- Emission sound pressure level: <70 dB (A).
- The lifters max load capacity has been tested with 10% dynamic overload and 25% static overload.

WEEE, RoHS and REACH



TAWI follows the WEEE (Directive 2012/19/EU), RoHS (2011/65/EU) and REACH (EC 1907/2006) regulations.

A used battery and/or circuit board should either be returned to an authorised TAWI representative or handed over to a station for chemical waste. All other parts can be discarded and assorted for recycling.

Do not make modifications

Welding and other mechanical modifications to TAWI CR80 or accessories must be carried out by TAWI authorised staff. According to ISO 3691-5, only if TAWI is no longer in business and there is no successor interested in the business, the user may perform a modification/alteration to a TAWI CR80. If this is done, the modification/alteration must be designed, tested and implemented by experts in TAWI CR80 and their safety. Also, a permanent record of the design, test(s) and implementation of the modification/alteration must be maintained. Appropriate changes to the capacity stickers, labels and user manual must be made, see *Markings and labels on the TAWI CR80*. A permanent and visible label must be fastened on the lifter that states how the lifter has been modified/altered together with the date it was performed. The name and address of the organisation that performed the modification must also be included.

Markings and labels on the TAWI CR80

TAWI	Model/Type:	Production year:
	Serial no.:	Voltage:
	Max load:	Effect:
		Net weight:
TAWI AB Transportgatan 1/Box 10205 SE-434 23 Kungälv SWEDEN www.tawi.com info@tawi.se		CE

TAWI	TAWI AB Transportgatan 1/ Box 10205 SE Kungälv Sweden		CE
Model/Type:	<input type="text"/>	Max load:	<input type="text"/>
Serial no.:	<input type="text"/>	Net weight:	<input type="text"/>
Production year:	<input type="text"/>	Distance to COG:	<input type="text"/>
			www.tawi.com info@tawi.se

Labels on TAWI CR80



 Do not use as a passenger lift! Do not stand underneath a raised tool.



 Risk of hands and feet getting caught in machine! Do not put hands or fingers on the mast or close to the sleigh or belt. Risk of crushing/pinching!



 Do not stand on or rest your feet on the legs or battery casing!



 This symbol precedes stated max load capacity. Never exceed the indicated max load capacity! Also see *Loading on page 14* for information on how to load.

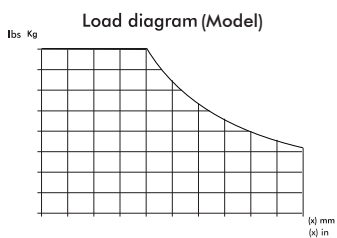

 Always load according to the load diagram sticker. See *Loading on page 14*.
Note that this sample sticker has no numbers on the axes, see the real sticker for numbers on your model.

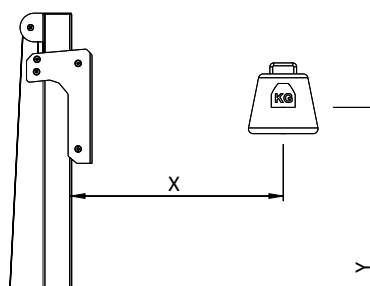

 These stickers provide information about x and y-distances. See *Loading on page 14*.



Read manual instructions! The operator must read and understand this manual before using the lifter.



Take precaution!



Always transport the lifter with the load LOWERED

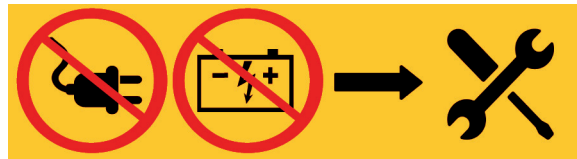

Disconnect power supply before servicing.

Label on the Coregripper tool

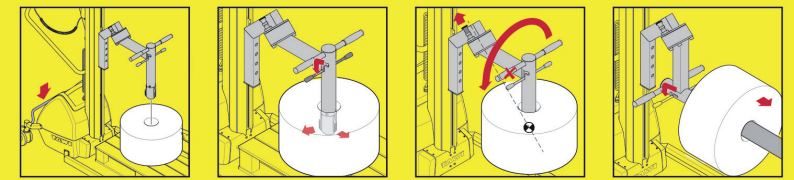

Sticker explaining handling and usage of the Coregripper tool.

2 Warranty

This chapter presents warranty information about the TAWI CR80

If a TAWI CR80 is used according to all instructions in this manual it will perform well for many years. TAWI offers a one year limited guarantee, excluding transportation charges, provided that the lifter has been used under normal working conditions (one shift and then recharged) and in accordance with the instructions in this manual. Non compliance with rules and instructions in this manual will result in complete exclusion of TAWI's liability.

Please contact info@tawi.com or your TAWI representative for further information.

3 Overview

TAWI CR80 provides lifting and transportation aid for loads up to 80kg (176lbs). The lifter can be equipped with different tools that have battery driven lifting and lowering capabilities. The user moves the lifter by pushing it, and prevents it from moving when stationary with the aid of brakes.

This chapter presents an overview illustration of the lifter and a table containing characteristics of the model. Important information about how to load the lifter is also provided.

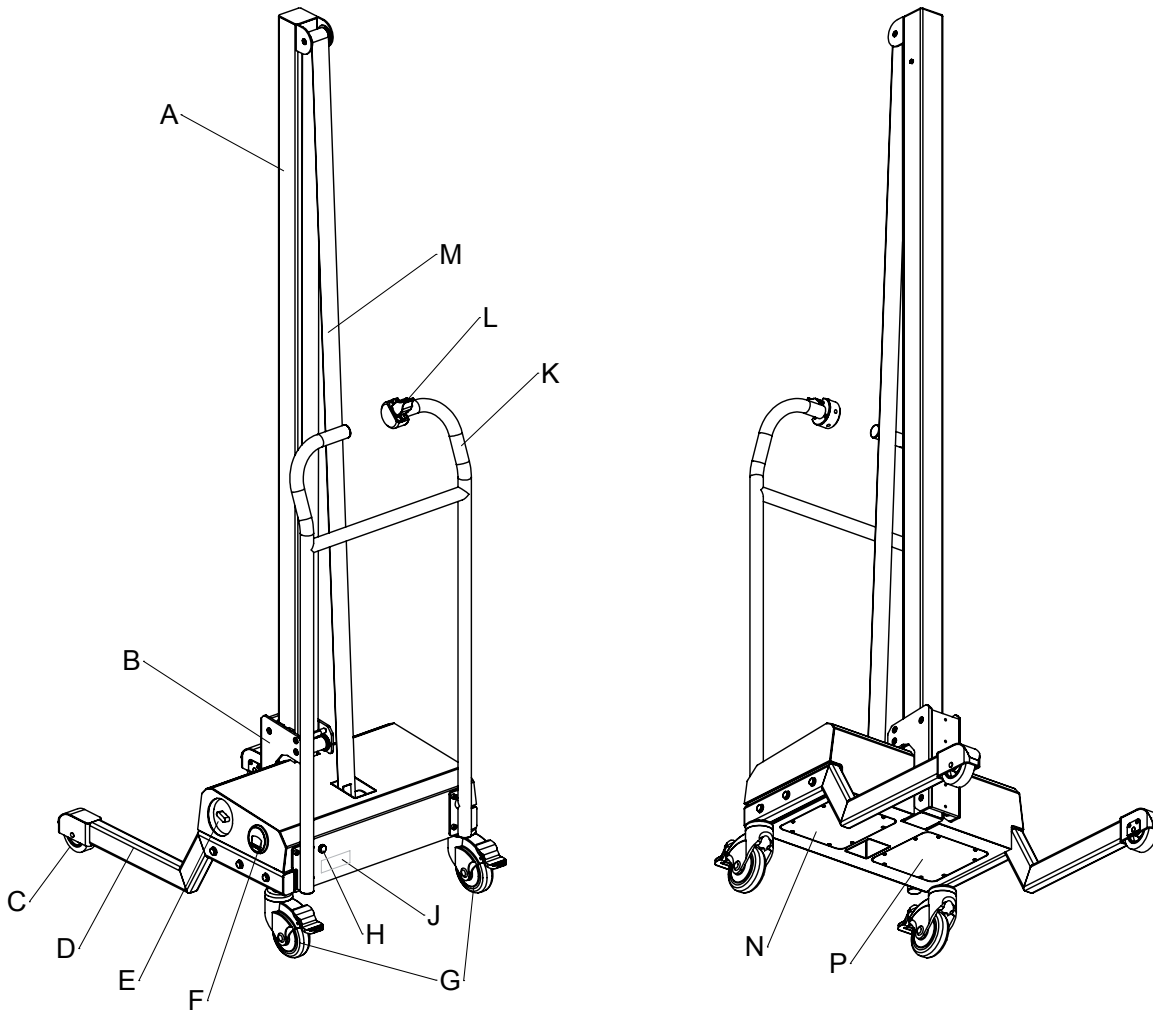



- A Mast
- B Sleigh
- C Front wheels
- D Leg
- E Charger lid
- F Battery status display
- G Rear wheels separately braked

- H Gore membrane
- J Identification plate
- K Handle
- L Joystick
- M Belt
- N Motor cover
- P Battery pack



This table presents information about STANDARD CONFIGURATION of ^{TAWI} CR80

Model	CR80
Lifting capacity	80kg/ 176lbs
 <p>The lifting capacity is valid only in accordance to the appropriate load diagram, see Loading on page 14.</p> <p>The max lifting capacity specified above are valid for standard configurations of the lifters. Check the sticker on the mast for applicable max load.</p>	
Max lifting height	2000mm/ 79in
 <p>The max lifting height specified above concern lifting height with preserved max lifting capacity. This is valid for standard configurations of the lifter.</p>	
Weight	46kg / (101lbs)
 <p>The weight is valid for standard configurations of the lifters without tools.</p>	
Battery charging procedure	Plug in to electrical outlet (100-240 V, grounded, 50-60 Hz) Recommended 8 hours continuous char
Lifts per charge	80kg (76lbs), 1m (39.3in), x 100 times
Up and down motions	Joystick, variable speed
Front wheels	Fixed
Brake system	Rear wheels separately braked
Overload protection	Incorporated in circuit load

Loading

The max lifting capacity of the lifter depends on where the mass centre of the load is located in terms of x and y distances. The graphs in the load diagrams display allowed x-distances and the text above each load diagram presents allowed y-distances.

CR80

Illustration of x and y-distances

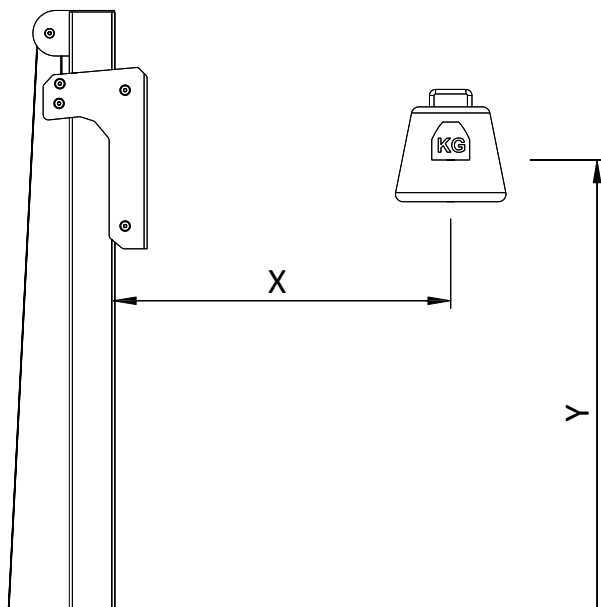

Load diagram CR80

Valid for y-distances between 0-2000mm (0-79in).

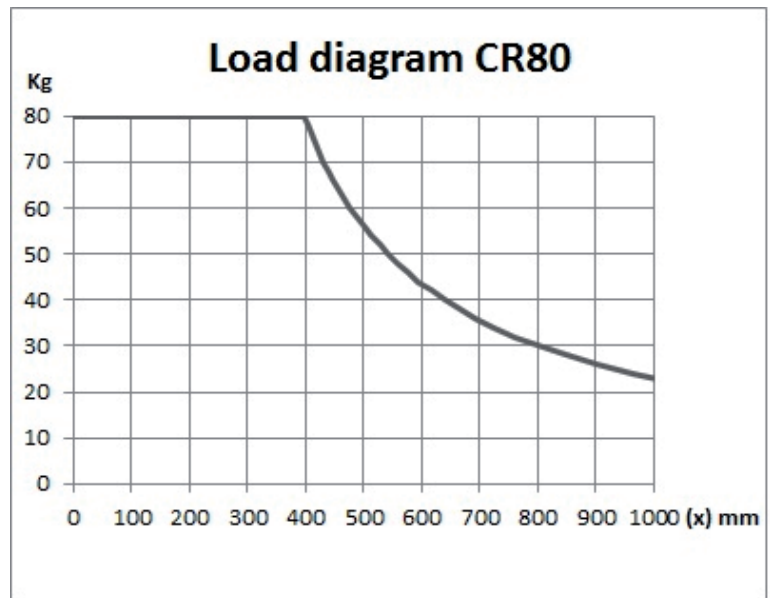

4 Quick start

This chapter presents how to fasten tools and how to start the lifter.

Fasten tools on the sleigh

Sometimes tools are attached at delivery. If not, attach the tool to the sleigh with at least three screws. Select which holes to use in order to get the desired max and min lifting heights.

1. Align the selected holes for attachment on the tool with the ones on the sleigh.
2. Fasten with at least three screws.

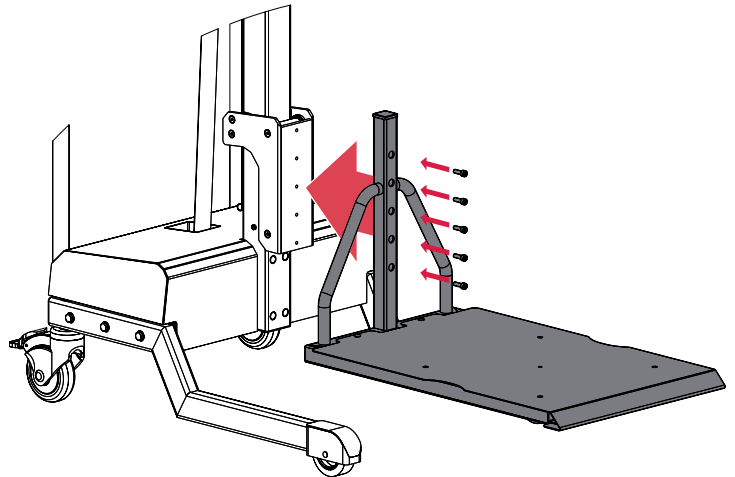

- Make sure the screws are fastened correctly and that the correct torque is applied on each screw.
- Make sure the screws are dimensioned to carry the weight of the tool plus the max load.

Torques to apply

Tool attachment for model	Type	Torque (Nm, class 8.8) (ft/lb)
CR80	M6	10 Nm (7.3 ft/lb)

5 User instructions

This chapter describes how to operate the TAWI CR80.

Start the lifter

Make sure that the wheels rotate smoothly, that the brakes on the rear wheels are functioning properly and that the battery is charged. Review and perform relevant inspections. See Daily inspections by operator on page 23, Quarterly inspections by inhouse maintenance on page 24 and Yearly inspections by TAWI authorised service technician on page 24.

1. Push the joystick up or down to turn on the unit.
 - » Response: The battery status display is lit up and lift is ready for use.
2. The lifter is now ready for use.



- Only run the lifter when it is completely assembled.



- Check the lifter for safe functionality prior to each use, for instructions, see Inspections on page 23.
- The lifter has overload protection which will prevent tools from being raised when the specified max load is exceeded. If the overload protection is activated, reduce the load and try again.
- The lifter will automatically turn off when joystick is released. There is an automatic build in on/off switch in the system which only turns unit on as soon as the joystick is being operated.

Charge the battery

The battery can not be overcharged or charged too often. It is recommended to charge the battery as soon as it is not in use.



- A damaged power cord could cause electrical shock.
- Never touch any parts inside the battery pack when charging. Touching electrical parts can cause an electric shock.



- The lifter can be switched on or off when charging the battery. It is recommended that the lifter is switched off.
- To make sure not to damage the cord when pulling it out of the electrical outlet - grab, and apply the force to the plug.
- It is recommended to charge the battery in a full cycle, however the battery system can be plugged in for a longer period, since it cannot be overcharged. See Battery charging indicator on page 19.
- Never operate the lifter when the battery is charging (plugged in).
- The battery system has to be charged in a grounded electrical outlet.
- Charge the battery in a designated dry area.
- Normal charging of the battery creates very small amounts of hydrogen. However, the casing has a lid that must be opened during charge, and thereby the risk of hydrogen collection is minimal.

Charge battery

1. Connect the power cord to a grounded electrical outlet (100 - 240 V, 50 - 60 Hz).
2. Open the lid by loosen the wingbolt.
3. Plug the charger plug into charger inlet on CR80.
4. When the battery is charged, pull the power cord out of the electric outlet and unplug from charger inlet on trolley.
5. Make sure to secure the lid properly.

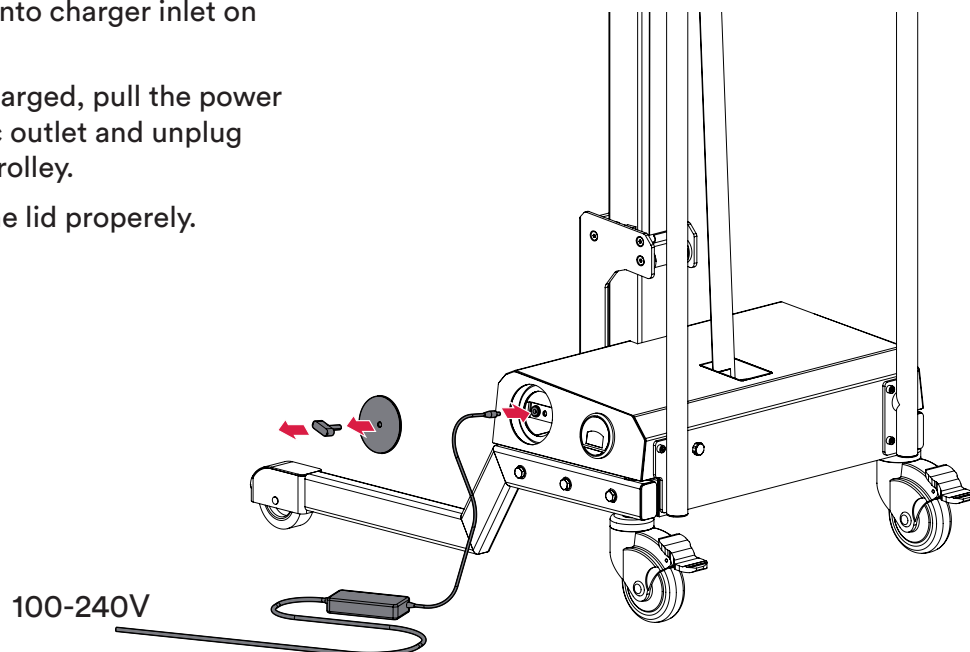



Battery charging indicator

The colour of the battery charging indicator communicates the following information:

CR80	
Orange	Boost charge
Yellow	Top up charge
Green	Ready/standby

Move the lifter

Grab the handles and push the lifter to move it forward.



Always move the lifter with the load in a lowered position.

Apply brakes to the lifter

There are two different brake options depending on the model of the lifter; rear wheels separately braked or central brake.

Rear wheels separately braked

Engage or disengage the brakes on both rear wheels.

- A. Neutral
- B. Brake

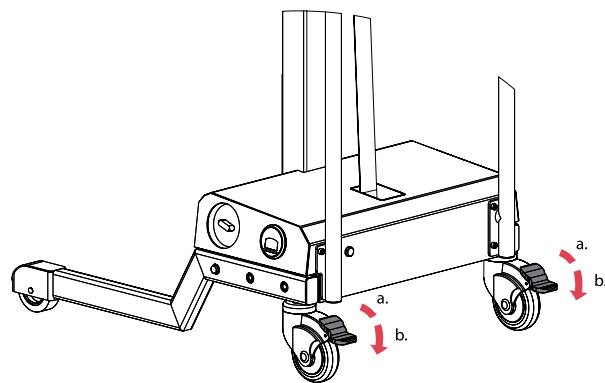

Always apply brakes when loading and unloading.



Operating tools

Tools are handled using a joystick placed on the right hand side of the handlebar.



If a tool hits an object or surface during lowering, a safety mechanism will stop the downwards movement. This is to prevent accidents.

Raise and lower with the joystick

The hand control can be detached from the handle and has two buttons, up and down. The hand control is equipped with two speeds. Press firmly for faster movement and press lightly for slower movement.

- A. Push joystick lever upwards to raise
- B. Push joystick lever downwards to lower

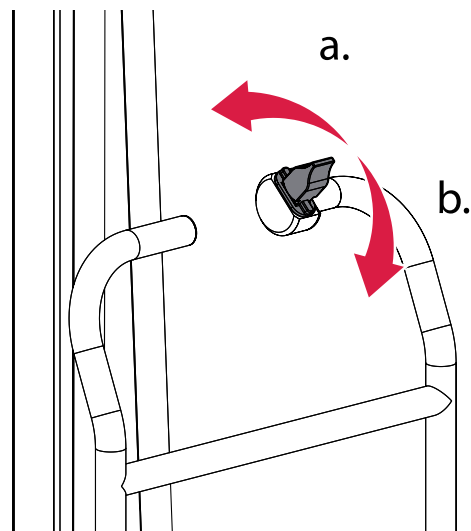

Battery status display

The battery status is indicated by the number of lit bars in the battery status display. Always charge when bars reach 50% level.





General tools

General tools includes platforms, fork tools etcetera, see Tools on page 28 for additional examples. These can be used to raise and lower loads and objects using the joystick.



- Make sure that the load is stable and is secured on the general tool.
- Make sure the general tool is loaded according to load diagrams, see Loading on page 14.
- Always transport a load in a lowered position.



Coregripper

The Coregripper is a reel handling tool that handles the reel from the core. It is designed to handle reels with a cardboard core. See Control panel on page <?> for illustrations of the buttons to use when operating an electrical Coregripper.

Pick up and rotate a reel



Always stay clear of the area under the reel.



- The Coregripper is mainly designed to pick up reels with the core in a vertical position.
- When lifting reels with the core in horizontal position, the reel can fall off the Coregripper. Make sure there is a secure grip before rotating.

1. Move the lifter and place the centre of the Coregripper above the core of the reel.



Apply brake to the rear wheels.

2. Push and hold the lever downward on the joystick
3. Release the lever when the Coregripper has reached desired depth.
4. Activate the gripping jaws by lifting the extractor handle out of its slots. Use both hands.
5. Push and hold the lever upward on the joystick
6. Raise the reel approximately 20cm (7.8in) from ground level to check that the core is gripped safely.



Make sure nobody is close to the lifter when preparing to rotate the reel.

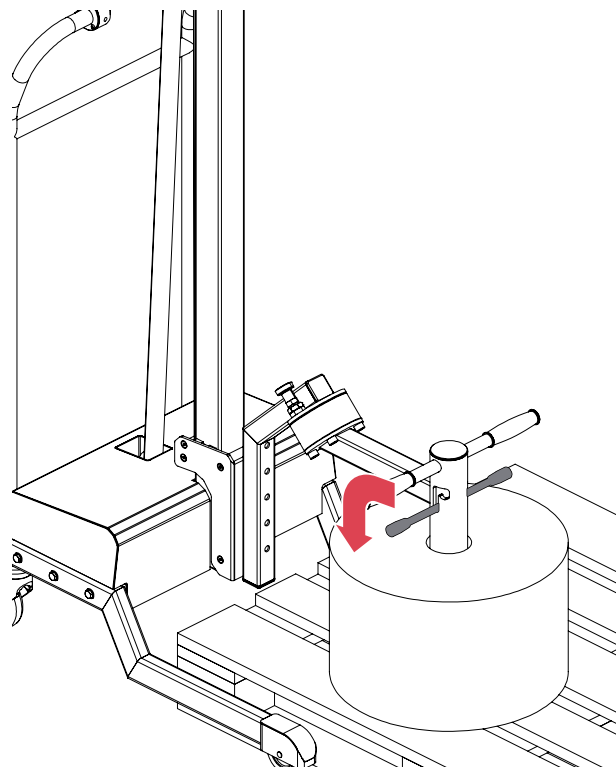
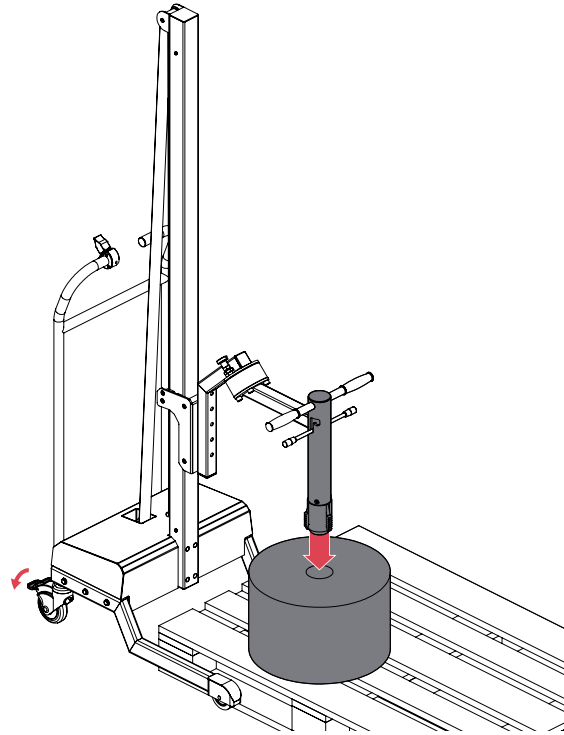



1. Rotate the Coregripper to horizontal position by grabbing the OPPOSITE side of the handle from the side you stand with reference to the mast.
2. Pull the rotation lock pin outwards and hold.
3. Pull the handle to rotate the reel.
4. Carry the rotation through before putting the rotation lock pin back gently.



For an effortless rotation, try to place the reel so that its center of gravity ends up on the axis of rotation.

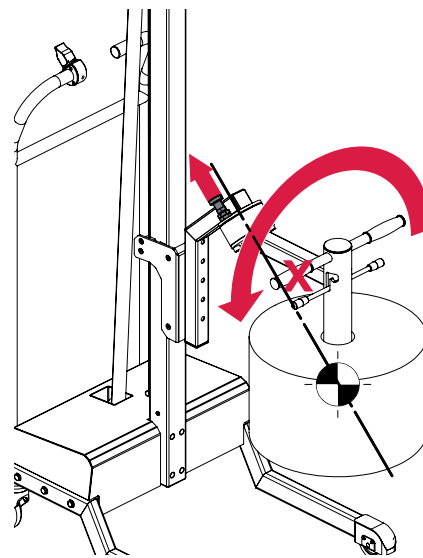

Transport a reel

1. Release the brake and push the lifter to desired location



- Always transport the reel with the core in horizontal position.
- Always transport objects at a lowered position.

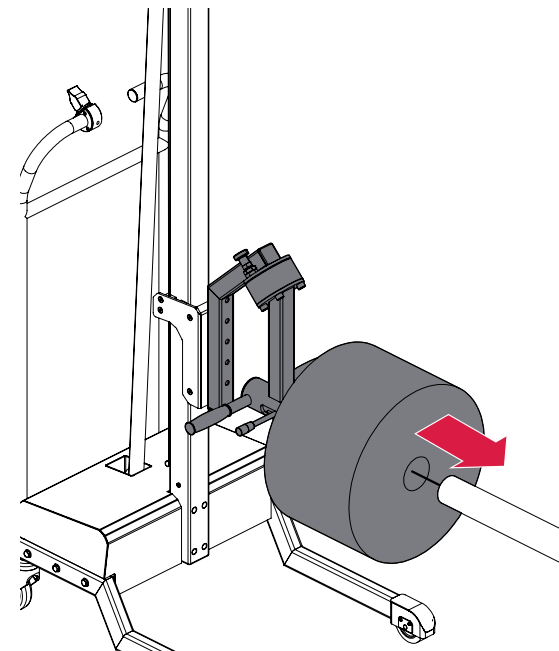

Release a reel onto a shaft

1. Push the lifter and raise the Coregripper to desired height (until it is in line with the shaft).



Make sure brakes are applied to the rear wheels when handling the reel.

2. Disengage the gripping jaws by putting the extractor handle back in its slots.
3. Manually push the reel onto the shaft.

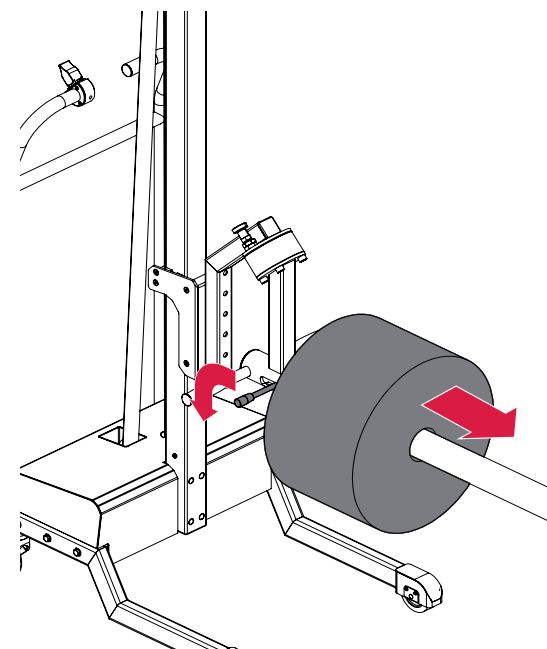

6 Service & maintenance

This chapter provides information about service and maintenance of the lifters. The chapter is divided into three sections based on who is to perform the inspections and how often the inspections are to be carried out. Daily by the operator, quarterly by inhouse maintenance or yearly by TAWI authorised service technician.

For technical service, maintenance or repairs contact your TAWI representative or info@tawi.com. TAWI must authorise all modifications to this product. TAWI assumes no responsibility for unauthorised modifications and guarantees will automatically become invalid if unauthorised modifications have been made.



- Service must be carried out on a yearly basis.
- If any damage/wear is detected on the lifter, this must immediately be reported to TAWI or authorised TAWI representative. The lifter must be taken out of commission and not be used until the damage has been repaired.
- All service must be carried out with the battery disconnected. The battery pack can be lifted out in order to remove the power source.
- In order to deal with the lifter's cables and wiring, a good knowledge of electricity and TAWI electrical schedules of the lifters is required.



- If the battery needs to be replaced, either order a new battery pack from TAWI or make sure that an original battery is used. If assistance is needed, contact TAWI.
- Keep the lifter clean. Do not use chemical cleaners.

Inspections

The following inspections are to be carried out.

Daily inspections by operator

1. If yearly service has been carried out, make sure that the service inspection date is valid.
2. Check that the max lifting capacity signs are visible.
3. Check that warning and operating labels are visible.
4. Make sure wheels and bearings are functioning and running smoothly.
5. Make sure breaks are functioning correctly and check for signs of damage/wear.
6. Check external wiring for damage/wear.
7. Make sure that the joystick is functioning properly.
8. Lower the tool (without load) until it hits a surface or object close to the ground to check that the tipping safety function is working properly.

Quarterly inspections by inhouse maintenance

1. Double check (carry out) all daily inspections mentioned in Daily inspections by operator.
2. Check all screws and nuts for damage/wear.
3. Check belt for wear and other damages.

Yearly inspections by TAWI authorised service technician

1. Check that CE mark and serial number on the identification plate are visible.
2. Make sure all screws and nuts are tightened according to Torques to apply on page 15.



3. Pay extra attention to screws and nuts on mast, legs, tool attachments and EasySqueeze arms.
4. Make sure the tool is correctly attached and fastened securely.
5. Check belt wheels for signs of damage/wear.
6. Check the belt for wear and tear and make sure that it is properly secured in belt lock.
7. Make sure that upper and lower switches are functioning correctly.
8. Control that the battery voltage level is sufficient.
9. Control that the charger is supplying correct voltage.
10. Check all wiring for signs of damage/wear and make sure all connections are correct.
11. Make sure that overload protection is functioning properly by test lifting with 10% overload according to indicated max load capacity.
12. Control screws and safety functions on tools e.g. springpins, safety locks etc.
13. Control welds for damage/wear on legs and tools caused by misuse, overload etc.

Torques

Type	Torque (Nm, class 8.8) (ft/lb)
M5	6 Nm (4.4 ft/lb)
M6	10 Nm (7.3 ft/lb)
M8	24 Nm (17.7 ft/lb)
M10	47 Nm (34.6 ft/lb)

Service of batteries or circuit board

1. Place trolley on table/floor with full access to the underside.
2. For change of batteries/controlboard, unscrew the left cover underneath the chassis (view from operator side).
3. Remove batteries carefully and put battery pack on a table/floor.
4. Do the repair/change of needed parts on battery pack.
5. Place battery pack back into place and secure all screws firmly.
6. Lower the tool (without load) until it hits a surface or object close to the ground to check that the tipping safety function is working properly.



- Always disconnect all cables to the battery before proceeding with any service/repairs.

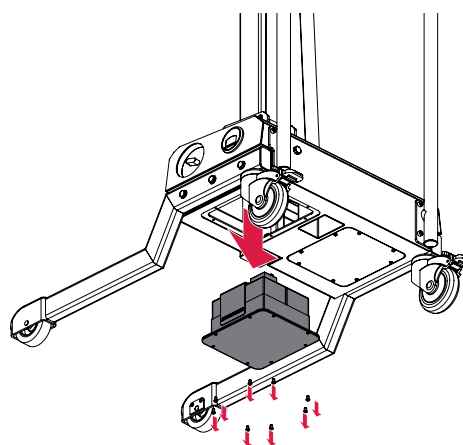

Changing the belt

1. Remove the two screws attaching the belt to the sleigh. Release the belt from the shaft.
2. Unwind (manually) the remaining part of the belt from the attachment in the centre of the chassis.
3. Remove the two screws holding the shaft to release the belt completely.
4. Attach the new belt to the chassis shaft. Install the other part of the belt to the sleigh shaft and mount all screws.



- Move the platform into the lowest position before starting with the belt change.
- Make sure that belt is wound up in correct direction when changed.

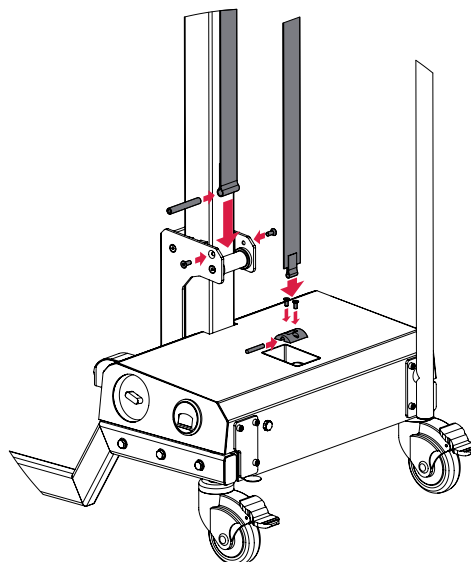

7 Troubleshoot

This chapter provides information on how to investigate or rectify problems that may occur. Actions marked with (*) must be carried out by TAWI or a TAWI authorised service technician.

Main unit

Problem	Likely caused by	Action required
Tool does not move up or down	Main switch is turned off.	→ Move joystick up/down
	Emergency stop is engaged.	→ Disengage the emergency stop.
	Batteries need charging.	→ Charge batteries according to manual. See page 17.
	Batteries are drained.	→ Change batteries.*
	Charger is damaged.	→ Check if charger supplies correct voltage, if not replace charger.*
	Overload protection is activated.	→ Reduce load to max stated capacity.
	Limit switches are broken/damaged.	→ Check functions of limit switches, replace if needed.*
	No signal from joystick.	→ Check if the joystick or connection cable are damaged. Replace if necessary.
	No signal from on/off board.	→ Check signal from the on/off board. Replace if necessary.
	Wires or connections are loose in battery pack.	→ Check wire connection on batteries. Connect if necessary.
	Fuse has tripped.	→ Check fuse, replace if broken.
Circuit board damaged.	→ Replace circuit board.*	
Tool moves slowly up/down	Batteries are weak.	→ Charge batteries according to manual.
	Excessive friction in sleigh.	→ Check if sleigh moves smoothly upwards with manual force, if jammed, contact a TAWI authorised service technician.*
Tool moves wrong direction	Belt have been wound up in wrong direction on belt roll	→ Wind up belt in correct direction



Problem	Likely caused by	Action required
Noise from belt drive	Belt transmission is worn in an inappropriate way.	→ Check belt and belt wheels for wear, replace if needed.*
Brake does not work	Brake has been misused.	→ Replace rear wheels.



8 Tools and accessories

This chapter presents a selection of tools and accessories designed for TAWI Lifting Trolleys.

Tools

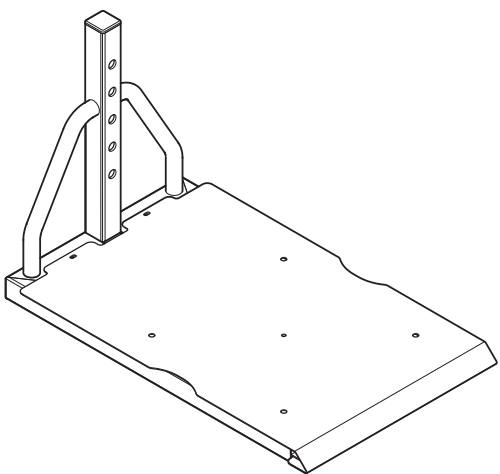

Platform 600×400mm (23.6×15.7in) (LxW)
Two surface materials: stainless steel and checker plate.

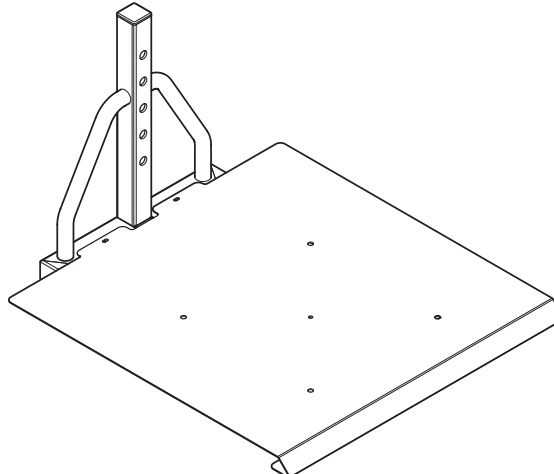

Platform 600×600mm (23.6×23.6in) (LxW)
Surfaces materials: stainless steel and checker plate.

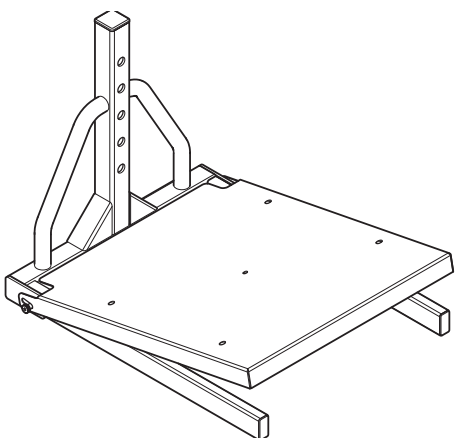

Fold up platform 500×440mm
(19.6×17.3in) (LxW)

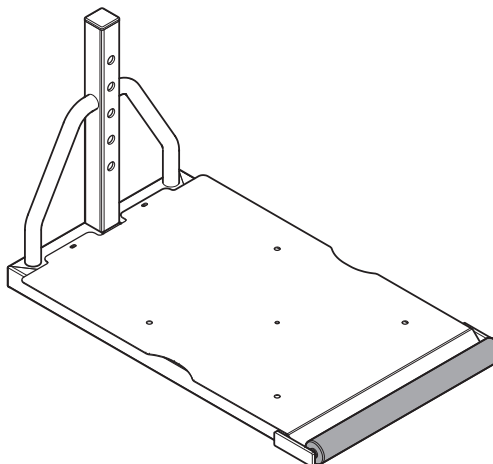

Loading roller
Suitable for all platforms except the fold up platforms.

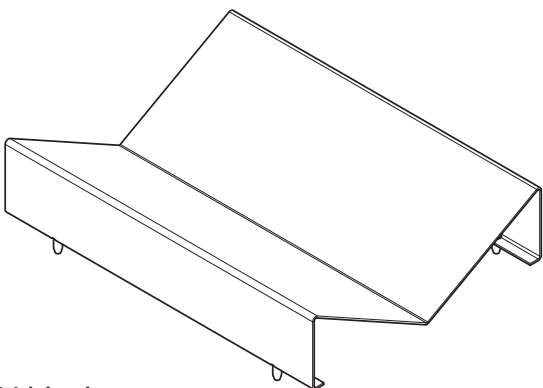

V-block
Suitable for all platforms.

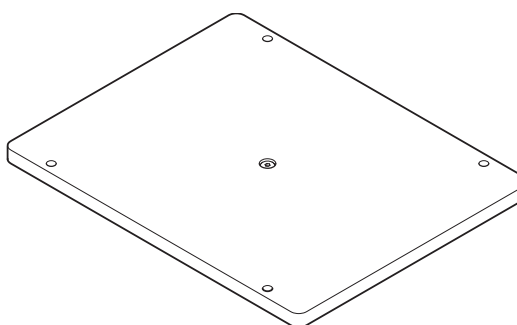

Rotating plate for V-block
Suitable for all platforms with stainless steel

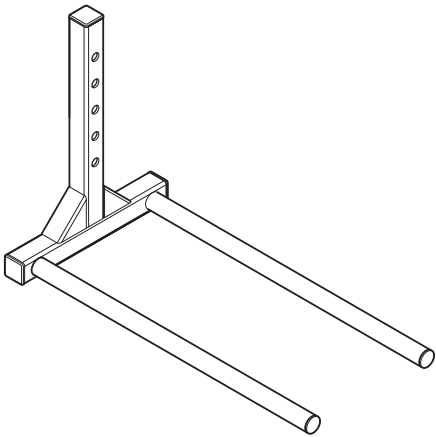

Tube fork L=600mm (L=23.6in)

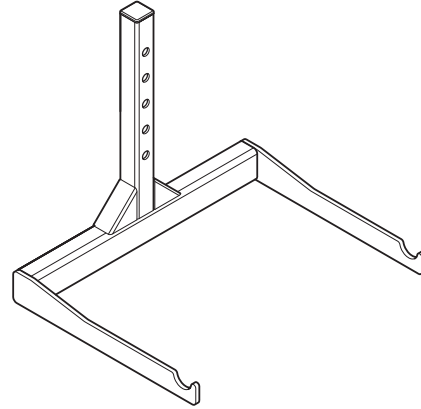

Fork for shafts

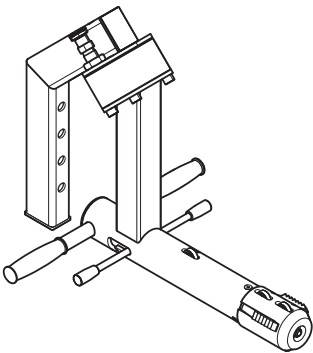

Coregripper Ø76

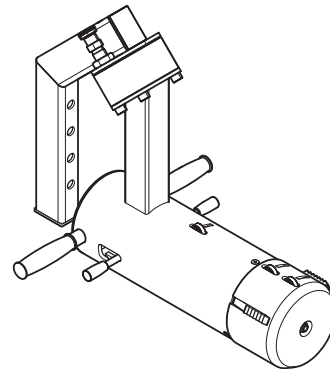

Coregripper Ø152

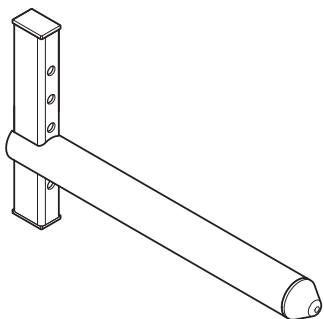

Boom L=500mm (L=19.6in)
Boom L=1000mm (L=39.3)



Appendix I

Load test certificate.

TAWI

Load test certificate

This certificate covers:

- Standard lifters or
- Derivative lifters with special tools

It is reproduced from the master TYPE certificate produced by the manufacturers and specified below.

Product: Protema lifter

Certificate type: 17-SKM-CM-0100

Manufacturer: TAWI AB, BOX 10205, 434 23 KUNGSBACKA, SWEDEN

Type of tool/special project:

Serial number:

The product is tested according to Machine Directive 2006/42/EG with Safe Working Load (SWL):

SWL:

I certify on behalf of the above company that the above item is fit for the purpose at SWL specified above:

Date:

Signature:

Appendix II

Inspection record. Keep the last page empty for copying in case records run out.

TAWI

Inspection record

Update the inspection record after each yearly inspection.

Date:	Stamp of approval
Signed:	
Next inspection date:	
Date:	Stamp of approval
Signed:	
Next inspection date:	
Date:	Stamp of approval
Signed:	
Next inspection date:	
Date:	Stamp of approval
Signed:	
Next inspection date:	
Date:	Stamp of approval
Signed:	
Next inspection date:	

TAWI

Inspection record

Update the inspection record after each yearly inspection.

Date:	Stamp of approval
Signed:	
Date for next service:	

Date:	Stamp of approval
Signed:	
Next inspection date:	

Date:	Stamp of approval
Signed:	
Next inspection date:	

Date:	Stamp of approval
Signed:	
Next inspection date:	

Date:	Stamp of approval
Signed:	
Next inspection date:	

Date:	Stamp of approval
Signed:	
Next inspection date:	

TAWI

Inspection record

Update the inspection record after each yearly inspection.

Date:	Stamp of approval
Signed:	
Next inspection date:	

Date:	Stamp of approval
Signed:	
Next inspection date:	

Date:	Stamp of approval
Signed:	
Next inspection date:	

Date:	Stamp of approval
Signed:	
Next inspection date:	

Date:	Stamp of approval
Signed:	
Next inspection date:	

Date:	Stamp of approval
Signed:	
Next inspection date:	

Appendix III

Spare part and electrical diagram

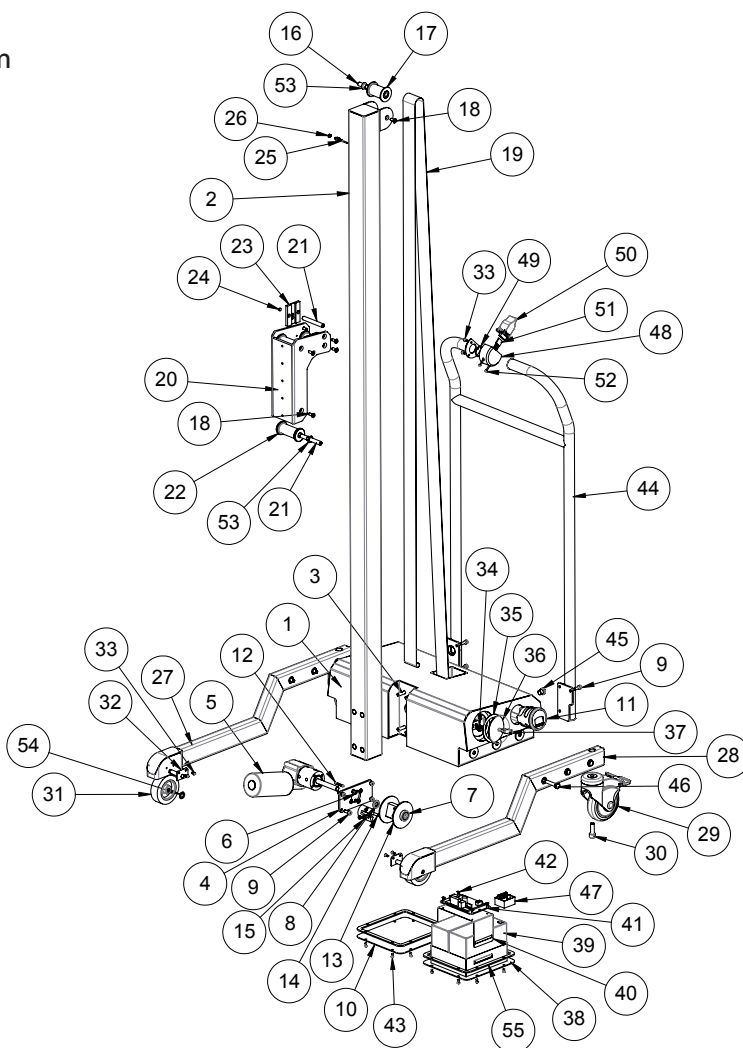

No	Qty	Description	Dimension	Material	Part Number
1	1	Chassis CR80		EN 1.4301	888001
2	1	Mast	L=1804	EN 1.4301	888002
3	4	Screw	M8x30	A4	MC6S M8x30 A4
4	1	Motor attachment	120x60x5	EN 1.4301	888003
5	1	Motor		8EMO120	8EMO121
6	6	Screw	MF6S M5x12 A4	A4	MF6S M5x12 A4
7	1	Bearing, motor shaft	Ø28/12x8		6001-2Z-SS
8	1	Shaft packing	12x21x04CC		881101
9	10	Screw	MC6S M6x20 A4	A4	MC6S M6x16 A4
10	1	Motor and battery cover	186x172 t=2	EN 1.4301	888004
11	1	Battery Indicator 24.0V			8EBA15
12	1	Key for chain sprocket			8027105
13	1	Belt roll part A	Ø70x53	Accetal (White)	881011
14	1	Shaft, belt roll	Ø6x40	EN 1.4301	881110
15	1	Belt roll part B	Ø40x42,5	Accetal (White)	881012

16	1	Wheel shaft, mast	Ø10×53,9	EN 1.4301	881031
17	1	Top wheel	Ø40×53	Accetal (White)	881030
18	10	Screw	MF6S M6×16	A4	MF6S M6×16 A4
19	1	Belt	L=?		881013
20	1	Sleigh		EN 1.4301	888005
21	4	Wheel shaft, sleigh	Ø10×74	EN 1.4301	881024
22	3	Sleigh wheel	Ø36×73,5	Accetal (White)	881023
23	2	Guideplate	58×46×6,5	Accetal (White)	881022
24	2	Magnet	Ø7×3		881105
25	2	Magnetic sensor			80224411
26	2	Nut	ML6M M5 A4	A4	ML6M M5 A4
27	1	Right leg		EN1.4301	888006
28	1	Left leg		1,4301	888007
29	2	Rear wheel	Ø100×30		881102
30	2	Screw	MC6S M10×30 A4	A4	MC6S M10×30 A4
31	2	Fixed front wheel	Ø80×24		882102
32	2	Front wheel axle			882003
33	7	Screw	K6S M4×8 A4	A4	K6S M4×8 A4
34	1	Charger inlet	2.5 mm		888012
35	1	Rubber seal	Ø76/60×1	Rubber	888011
36	1	Cover plate	Ø76×2	EN 1.4301	888008
37	1	Thumb screw	M6×25	EN 1.4301	881112
38	1	Battery box		EN 1.4301	888009
39	2	Battery	12V 7Ah		8eba102
40	1	Circuit board holder	284.7×71×1	EN 1.4301	881004
41	1	Curcuit board			8ecb003
42	4	Screw	MF6S M3×5 A4	A4	MF6S M3×5 A4
43	16	Screw	MK6S M4×8	A4	MK6S M4X8 A4
44	1	Handlebar		EN 1.4301	888010
45	1	GORE membrane			881145
46	6	Screw	M6S M8×40 A4	8,8	M6S M8×40 A4
47	1	On/Off control board			8eba16
48	1	Joystick bracket	Ø58×30	Accetal (Black)	882042
49	1	O-ring	27×2	EPDM	OR27×2
50	1	Joystick, JC120			8713061
51	1	Cable electric, joystick			8713886
52	2	Screw	MC6S M3×16	A4	MC6S M3×16 A4
53	8	Bearing		Accetal (Black)	H1FM 1012 10 1
54	4	Plastic washer	10,5×18×1,5	PA (White)	621105
55	2	Sealing, lid	3×10	Cellular rubber	888016

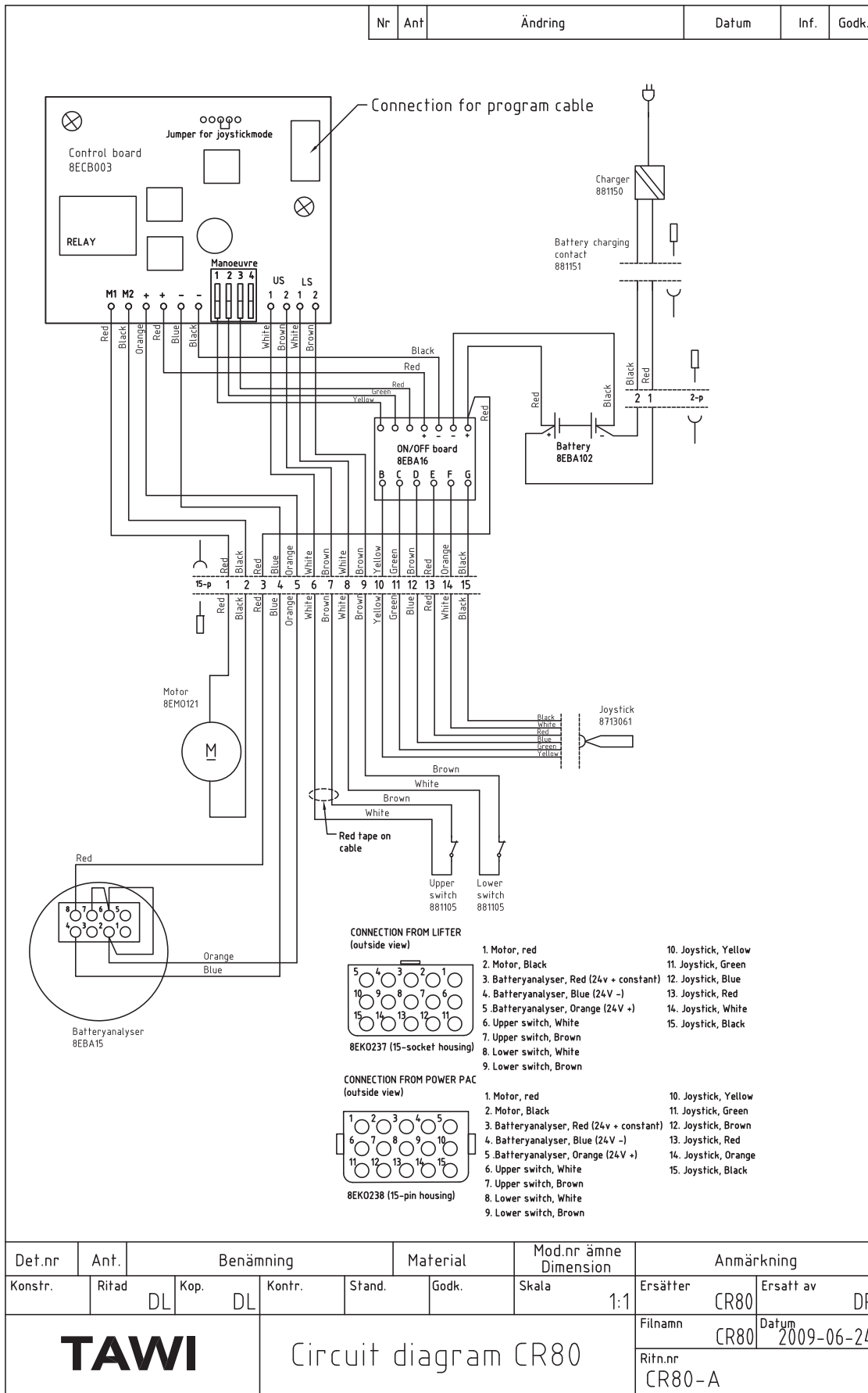





TAWI AB
Box 102 05
Transportgatan 1
434 23 Kungsbacka
Tel: +46 (0) 300 -185 00
Fax: +46 (0) 300 189 90
info@tawi.se

