

TAWI



CE

User manual for TAWI Lifting Trolleys (ENG)

Declaration of Conformity

According to 2006/42/EG Annex IIA

This manual and the Declaration of conformity is only valid when using TAWI authorised tools.

Manufacturer

TAWI AB

Box 10205, Transportgatan 1, 434 23 Kungsbacka, Sweden

Authorised representative

Name:

Company:

Address:

Machine description

Product group:

TAWI Lifting Trolleys

Product type:

Serial number:

It is hereby confirmed that the machine mentioned is in compliance with the following directives:

- 2006/42/EG Machine Directive
- 2014/30/EU EMC Directive

The following harmonised standards have been used:

- 12100:2010 Safety of machinery - General principles for design - Risk assessment and risk reduction
- SS-EN 349+A1:2008 Safety of machinery - Minimum gaps to avoid crushing of parts of the human body
- SS-ISO 22915-16:2015 Industrial trucks - Verification of stability - Part 16: Pedestrian-propelled trucks
- SS-EN ISO 3691-5:2015 Industrial trucks. Safety requirements and verification. Part 5: Pedestrian-propelled trucks
- SS-EN 12895:2015 Industrial trucks - Electromagnetic compatibility
- SS-EN 1175-1+A1:2010 Safety of industrial trucks - Electrical requirements - Part 1: General requirements for battery powered trucks
- SS-EN ISO 13849-1:2008 Safety of machinery - Safety-related parts of control systems - Part 1: General principles for design)
- SS-EN 60204-1 Safety of machinery – Electrical equipment of machines – Part 1: General requirements

Notified body:

Inspecta

Date:

Place:

Kungsbacka, SWEDEN

Signature:



Thomas Bräutigam, CEO TAWI Holding

Signature:



David Ranfalk, Responsible for the technical dossier



Declaration of Incorporation of Partly Completed Machinery

According to 2006/42/EG Annex IIB

A final certification is required before sending the lifter to an end customer.



Important

When receiving a Declaration of Incorporation of Partly Completed Machinery according to 2006/42/EG Annex IIB, a final certification according to 2006/42/EG Annex IIA is required before the lifter can be sent to an end customer.

The main part of this is to make sure that the lifter complies to SS-ISO 22915-16:2015 Industrial trucks - Verification of stability - Part 16: Pedestrian-propelled trucks and to perform a risk analysis.

Manufacturer

TAWI AB, Box 10205, Transportgatan 1, 434 23 Kungsbacka, Sweden

Authorised representative

Name:

Company:

Address:

Machine description

Product group:

TAWI Lifting Trolleys

Product type:

Serial number:

It is hereby confirmed that the machine mentioned is in compliance with the following directives:

- 2006/42/EG Machine Directive
- 2014/30/EU EMC Directive

The following harmonised standards have been used:

- 12100:2010 Safety of machinery - General principles for design - Risk assessment and risk reduction
- SS-EN 349+A1:2008 Safety of machinery - Minimum gaps to avoid crushing of parts of the human body
- SS-EN ISO 3691-5:2015 Industrial trucks. Safety requirements and verification. Part 5: Pedestrian-propelled trucks
- SS-EN 12895:2015 Industrial trucks - Electromagnetic compatibility
- SS-EN 1175-1+A1:2010 Safety of industrial trucks - Electrical requirements - Part 1: General requirements for battery powered trucks
- SS-EN ISO13849-1:2008 Safety of machinery - Safety-related parts of control systems - Part 1: General principles for design
- SS-EN 60204-1 Safety of machinery – Electrical equipment of machines – Part 1: General requirements

Notified body:

Inspecta

Date:

Place:

Kungsbacka, SWEDEN

Signature:

Thomas Bräutigam, CEO TAWI Holding

Signature:

David Ranfalk, Responsible for the technical dossier



Contents

1 Safety & important information	05
WEEE, RoHS and REACH	08
Do not make modifications	08
Markings and labels on the Protema lifters	08
2 Warranty	11
3 Overview	12
Loading	14
4 Quick start	16
Fasten tools on the sleigh	16
Lift the lifter	16
Torques to apply	16
5 User instructions	17
Start the lifter	17
Charge the battery	17
Battery charging indicator	19
Move the lifter	19
Apply brakes to the lifter	20
Adjust legs	21
Operating tools	22
6 Service & maintenance	30
Inspections	30
Torques	31
7 Troubleshoot	32
Main unit	32
Tools	34
Codes on the battery status display	35
8 Tools and accessories	36
Tools	36
Accessories	38

1 Safety & important information

This chapter presents safety information about the TAWI Lifting Trolley lifters (hereafter referred to as lifters). Some of the information is divided in Warning, Caution and Important. This division is based on the severity of the consequences that may occur if the instructions are not followed. Stickers and labels are explained in this chapter and information is provided about directives that TAWI follows.

This manual and the Declaration of conformity is only valid when using TAWI authorised tools.



WARNING: Risk of personal injuries or major material damages.



Caution: Risk of material damages.



Important: Important information is highlighted.

This is the original version of the Protema lifter user manual.



WARNING

- Before operating a lifter, this manual must be read and understood.
- Always apply brakes to the rear wheels when loading and unloading.
- NEVER exceed the indicated max load capacity on the lifter or on a tool. If a special tool is used, there might be a separate max load capacity indicated on the tool, make sure to always comply to both.
- Make sure to load according to the load diagrams including y-distances. See *Labels on TAWI Lifting Trolleys on page 09 and Loading on page 14*.
- Make sure loads are distributed evenly on the platform and always load according to load diagram.
- If any unexpected movement of the lifter occurs, press emergency stop.
- In case of emergency, engage the emergency stop, see *Control panel on page 23*. It is also possible to remove the battery pack from the lifter.
- Make sure to control and solve any potential errors before resetting the emergency stop.
- The operator's position should always be behind the lifter when it is used, also when using the hand control! From this position the emergency stop is within reach.
- Stay clear of the area underneath a tool at all times.
- Stay clear of moving parts.
- During all service and maintenance, lay the lifter down on the floor (on its back).
- Be careful when using a Protema ladder. Make sure you have a good grasp of a supporting object and that you have a good grip for your feet, see *Ladder on page 29*.
- In order to deal with the lifter's cables and wiring, a good knowledge of electricity and TAWI electrical schedules of the lifters is required. Faults can cause damage to people and property.
- NEVER climb on the lifter.
- NEVER stand on the cover or any other part of the lifter.



Caution

- The lifters are made for indoor use on a smooth, even floor/surface. Max allowed inclination is 4%.
- The recommended temperature range for the lifters is 10 - 50 degrees Celsius (50 - 122 degrees Fahrenheit). The lifting performance may vary when the temperature deviates from 20 degrees Celsius (68 degrees Fahrenheit).
- Make sure there is good lighting in areas where the lifter is operated.
- Use caution when passing over thresholds, floor drains, hoses or cables.
- Never spray or pour water onto the casing containing the battery, charger and motor. Clean with a damp cloth only. The lifters have IP code IPX4.
- Recharge the battery in a designated dry area.
- Any part of this lifter or accessories that show signs of wear or other damage must be replaced immediately. The lifter must not be used before the damaged part is replaced. A damaged power cord may only be replaced by TAWI authorised service technicians.
- Do not use the lifter while it is plugged into an outlet.
- Only run the lifter when it is completely assembled.
- Wear steel toe shoes with good grip when operating the lifter.
- Never manually move the tool past the top switch.
- There is always one top switch and one bottom switch assembled on the lifter. NEVER move the top or bottom switches.
- If the lifter is to be lifted, fasten a sling in the handle and lift. See *Lift the lifter on page 16*.



Important

- To prevent damages and injuries caused by improper use and not to compromise the warranty and liability: Follow the instructions in this manual at all times!
- The lifter is certified as a unit together with a specific tool. If the tool is changed, this must be checked with TAWI. If a tool is used that is not authorised by TAWI, a new final certification of the complete lifter must be implemented.
- Use the ^{TAWI} Lifting Trolley lifter or accessories only in accordance with all instructions in this manual.
- Keep this manual accessible to all staff.
- The lifters are not intended for use by persons (including children) with reduced physical, sensory or mental capabilities, or lack of experience or knowledge, unless they have been given supervision or instruction concerning use of the appliance by a person responsible for their safety. Children should be supervised to ensure that they do not play with the lifters.
- Due to a safety mechanism, if a tool hits an object or surface when lowered, it will stop immediately.
- Use only TAWI original spare parts.
- Always follow any local/national recommendations as well as the instructions in this manual.
- The lifter and accessories should only be used when they are in perfect working order.
- If the lifter is to be out of use for a longer period, ensure that the battery is maintained (not drained).
- Intermittent-duty: 15%.
- Emission sound pressure level: <70 dB (A).
- The lifters max load capacity has been tested with 10% dynamic overload and 25% static overload.

WEEE, RoHS and REACH



TAWI follows the WEEE (Directive 2012/19/EU), RoHS (2011/65/EU) and REACH (EC 1907/2006) regulations.

A used battery and/or circuit board should either be returned to an authorised TAWI representative or handed over to a station for chemical waste. All other parts can be discarded and assorted for recycling.

Do not make modifications

Welding and other mechanical modifications to TAWI Lifting Trolleys or accessories must be carried out by TAWI authorised staff. According to ISO 3691-5, only if TAWI is no longer in business and there is no successor interested in the business, the user may perform a modification/alteration to a TAWI Lifting Trolley. If this is done, the modification/alteration must be designed, tested and implemented by experts in TAWI Lifting Trolleys and their safety. Also, a permanent record of the design, test(s) and implementation of the modification/alteration must be maintained. Appropriate changes to the capacity stickers, labels and user manual must be made, see *Markings and labels on the TAWI Lifting Trolleys*. A permanent and visible label must be fastened on the lifter that states how the lifter has been modified/alterated together with the date it was performed. The name and address of the organisation that performed the modification must also be included.

Markings and labels on the TAWI Lifting Trolleys

Identification plate

TAWI	
Model / Type:	<input type="text"/>
Serial no.:	<input type="text"/>
Production year:	<input type="text"/>
Max load:	<input type="text"/>
Voltage:	<input type="text"/>
Effects:	<input type="text"/>
Net weight:	<input type="text"/>
 TAWI AB Transportgatan 1/ Box 10205 SE-434 23 Kungälv SWEDEN www.tawi.com info@tawi.se	

Tool Identification plate

TAWI TAWI AB Transportgatan 1/ Box 10205 SE Kungälv Sweden			
Model/Type:	<input type="text"/>	Max load:	<input type="text"/>
Serial no.:	<input type="text"/>	Net weight:	<input type="text"/>
Production year:	<input type="text"/>	Distance to COG:	<input type="text"/>
		www.tawi.com info@tawi.se	

Labels on TAWI Lifting Trolleys



 Do not use as a passenger lift! Do not stand underneath a raised tool.



 Risk of hands and feet getting caught in machine! Do not put hands or fingers on the mast or close to the sleigh or belt. Risk of crushing/pinching!



 Do not stand on or rest your feet on the legs or battery casing!



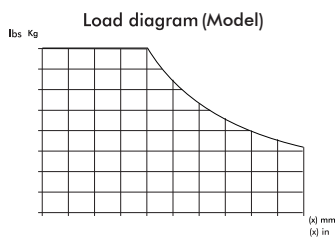

 This symbol precedes stated max load capacity. Never exceed the indicated max load capacity! Also see *Loading* on page 09 for information on how to load.



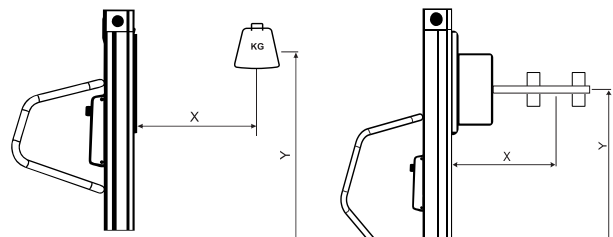

 Always load according to the load diagram sticker. See *Loading* on page 14.
Note that this sample sticker has no numbers on the axes, see the real sticker for numbers on your model.





 These stickers provide information about x and y-distances. See *Loading* on page 14.



 Read manual instructions! The operator must read and understand this manual before using the lifter.



 Take precaution!



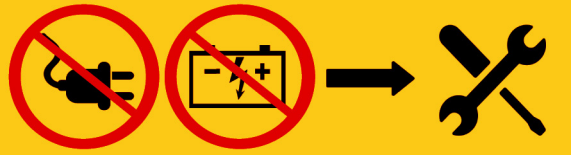

 Always transport the lifter with the load LOWERED

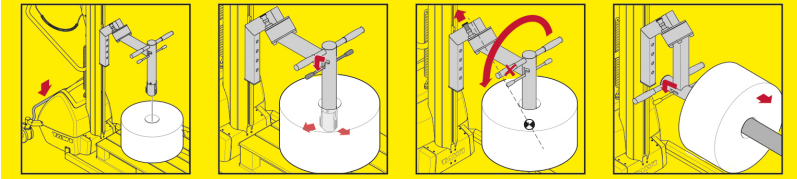

 Disconnect power supply before servicing.

Label on the Coregripper tool



 Sticker explaining handling and usage of the Coregripper tool, see *Coregripper* on page 27.

Label on Protema ladder



 Sticker explaining handling and usage of the Protema ladder, see *Ladder* on page 29.

Voltage and battery checked

120/230V 50/60Hz 40W

120/230V 50/60Hz 80W

Serial no:



2 Warranty

This chapter presents warranty information about the Protema lifters.

If a TAWI Lifting Trolleys is used according to all instructions in this manual it will perform well for many years. TAWI offers a one year limited guarantee, excluding transportation charges, provided that the lifter has been used under normal working conditions (one shift and then recharged) and in accordance with the instructions in this manual. Non compliance with rules and instructions in this manual will result in complete exclusion of TAWI's liability.

Please contact info@tawi.com or your TAWI representative for further information.

3 Overview

^{TAWI} Lifting Trolleys provide lifting and transportation aid for loads up to 250kg (551lbs). The lifters can be equipped with different tools that have battery driven lifting and lowering capabilities. The user moves the lifter by pushing it, and prevents it from moving when stationary with the aid of brakes.

The lifters are available in seven different models, mainly differing in lifting capacity: PRO40, PRO80, PRO140, PRO180, PRO250, PRO100ESE and PRO200ESE. This chapter presents an overview illustration of the lifters and a table containing characteristics of the different models. Important information about how to load the lifters is also provided.

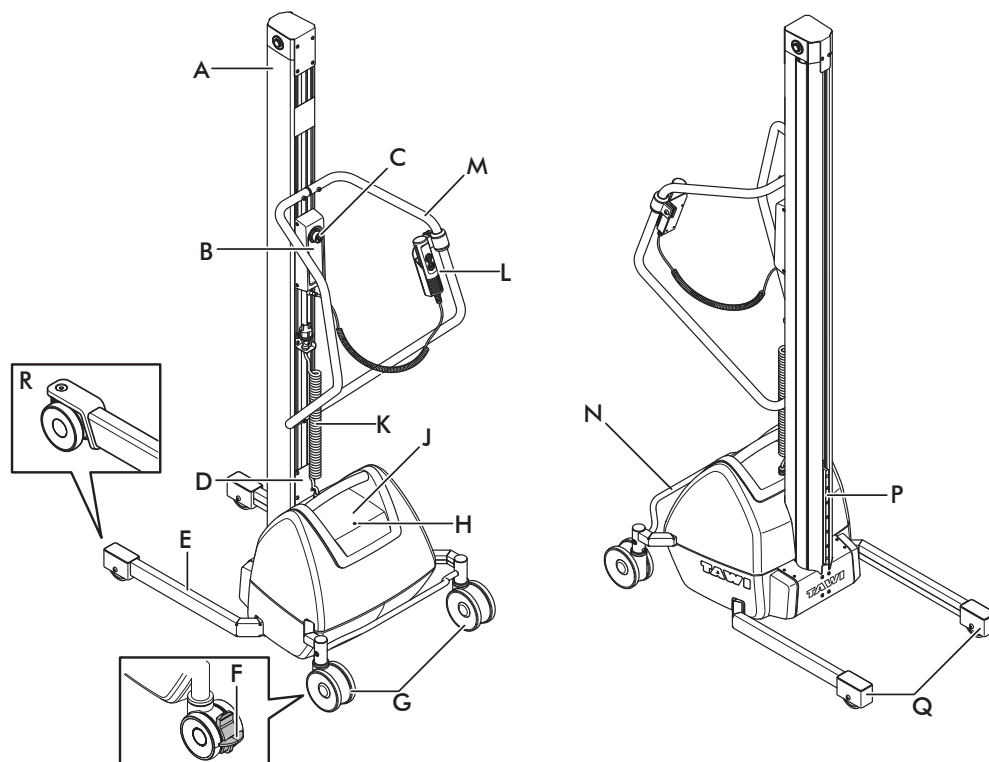

- | | |
|-----------------------------------------|--------------------------------------------|
| A Mast | J Battery pack |
| B Control panel | K Power cord |
| C Emergency stop | L Hand control (all models except PRO40) |
| D Identification plate | M Handle |
| E Leg | N Central brake |
| F Rear wheels separately braked (PRO40) | P Sleigh |
| G Rear wheels | Q Front wheels |
| H Battery charging indicator | R Swiveling front wheels (PRO40 and PRO80) |



This table presents information about STANDARD CONFIGURATIONS of each model.

Model	PRO40	PRO80	PRO140	PRO180	PRO250	PRO100ESE	PRO200ESE
Lifting capacity	40kg/ 88lbs	80kg/ 176lbs	140kg/ 308lbs	180kg/ 379lbs	250kg/ 551lbs	100kg/ 220lbs	200kg/ 441lbs
<p>The lifting capacity is valid only in accordance to the appropriate load diagram, see <i>Loading</i> on page 14. The max lifting capacity specified above are valid for standard configurations of the lifters. Check the sticker on the mast for applicable max load.</p>							
Max lifting height	1640mm/ 64.5in	2540mm/ 100in	2540mm/ 100in	2540mm/ 100in	2540mm/ 100in	2222mm/ 87.4in	2195mm/ 86.4in
<p>The max lifting height specified above concern lifting heights with preserved max lifting capacity. These are valid for standard configurations of the lifters.</p>							
Weight short/ medium/long mast	- / 41kg (90lbs) /-	46kg (101lbs)/ 50kg (110lbs)/ 53kg (116lbs)	69kg (152lbs)/ 73kg (160lbs)/ 78kg (171lbs)	77kg (169lbs)/ 81kg (178lbs)/ 86kg (189lbs)	- / 107kg (238lbs)/ 113kg (249lbs)	Electrical EasyTurn: - / 115kg (253lbs)/ 120kg (265lbs)	- / 152kg (335lbs)/ 158kg (348lbs)
						Manual EasyTurn: - / 113kg (249lbs)/ 118kg (260lbs)	
<p>The weight is valid for standard configurations of the lifters without tools.</p>							
Battery charging procedure	Plug in to electrical outlet (100-240 V, grounded, 50 - 60 Hz) Recommended 8 hours continuous charge						
Lifts per charge	40kg (88lbs), 1m (39.3in) x 100 times	80kg (76lbs), 1m (39.3in), x 100 times	140kg (308lbs), 1m (39.3in), x 100 times	180kg (397lbs), 1m (39.3in), x 100 times	250kg (551lbs), 1m (39.3in), x 100 times	100kg (220lbs), 1m (39.3in), x 100 times	200kg (441lbs), 1m (39.3in), x 100 times
Up and down motions	Control panel. One speed.	Hand control. Two speeds.					
Front wheels	Swiveling	Swiveling	Fixed				
Brake system	Rear wheels separately braked	Central brake with directional lock.					
Overload protection	Incorporated in circuit load						

Loading

The max lifting capacity of the lifters depends on where the mass centre of the load is located in terms of x and y distances. The graphs in the load diagrams display allowed x-distances and the text above each load diagram presents allowed y-distances.

PRO40, PRO80, PRO140, PRO180 and PRO250

Illustration of x and y-distances

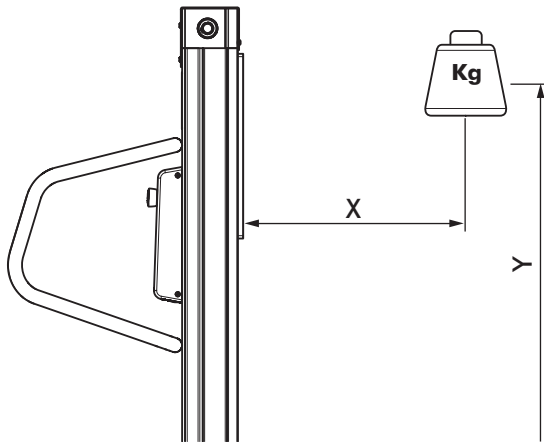

Load diagram PRO40

Valid for y-distances between 0 - 1640mm (0 - 64.5in).

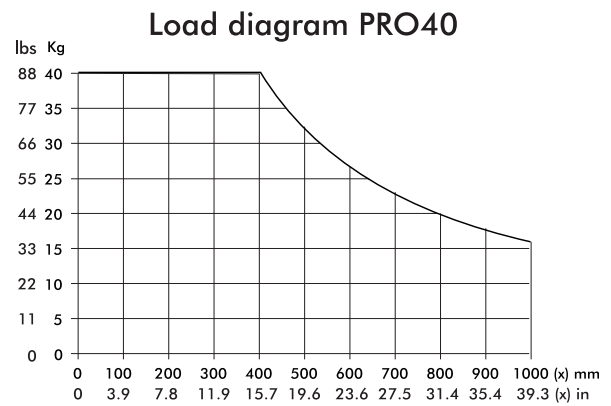

Load diagram PRO80

Valid for y-distances between 0 - 2540mm (0 - 100in).

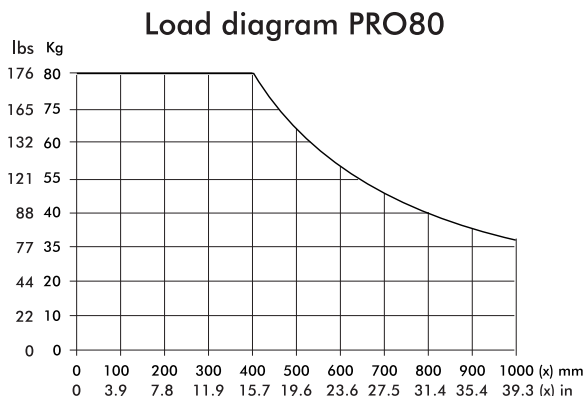

Load diagram PRO140

Valid for y-distances between 0 - 2540mm (0 - 100in).

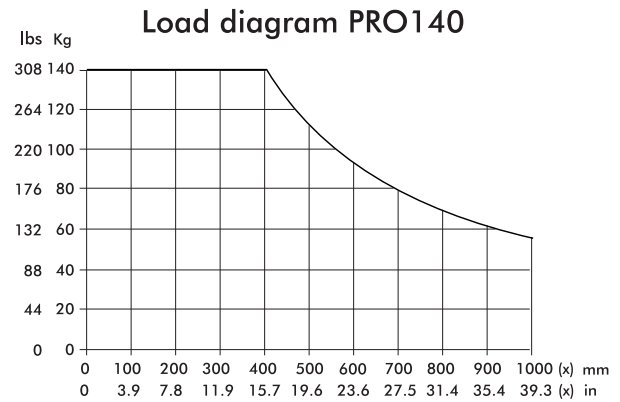

Load diagram PRO180

Valid for y-distances between 0 - 2540mm (0 - 100in).

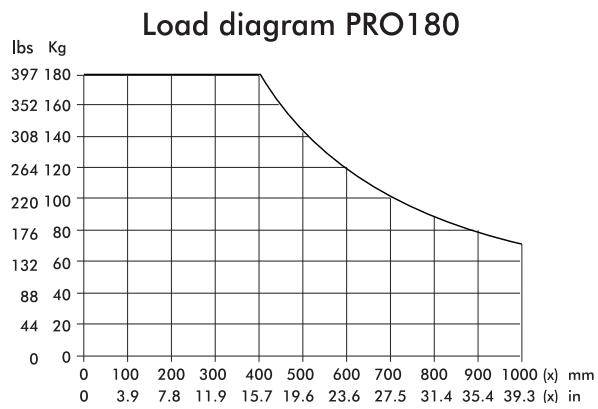

Load diagram PRO250

Valid for y-distances between 0 - 2540mm (0 - 100in).

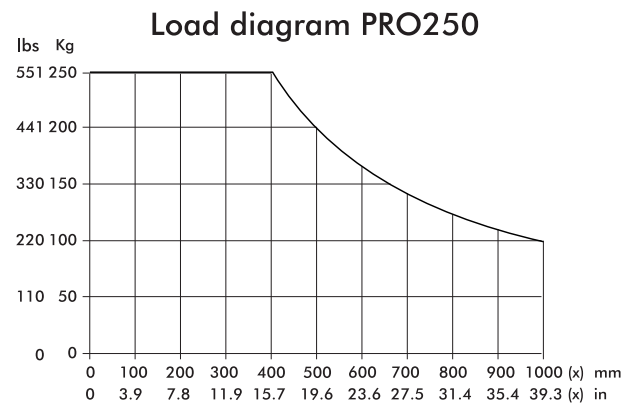

PRO100ESE and PRO200ESE

Illustration of x and y-distances

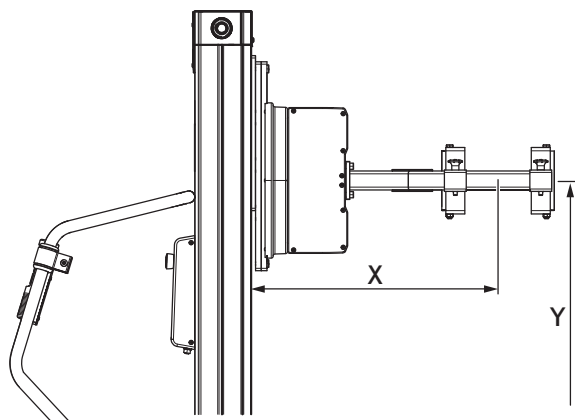

Load diagram PRO100ESE

Valid for y-distances between 0 - 2222mm (0 - 87.4in).

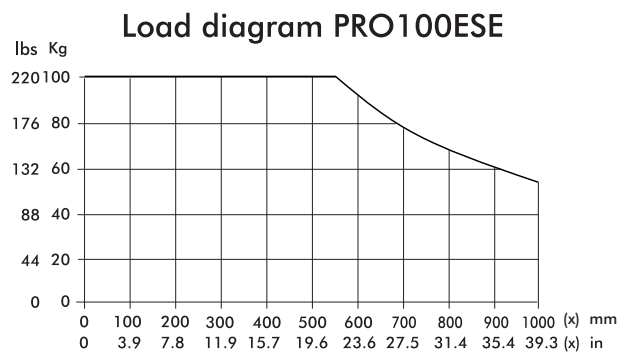

Load diagram PRO200ESE

Valid for y-distances between 0 - 2195mm (0 - 86.4in).

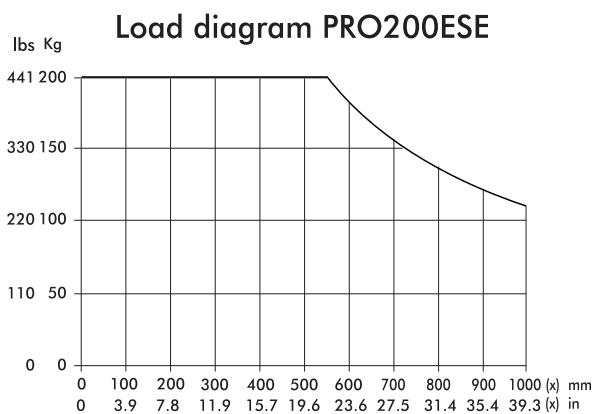

4 Quick start

This chapter presents how to fasten tools and how to start the lifter.

Fasten tools on the sleigh

Sometimes tools are attached at delivery. If not, attach the tool to the sleigh with at least three screws. Select which holes to use in order to get the desired max and min lifting heights.

1. Align the selected holes for attachment on the tool with the ones on the sleigh.
2. Fasten with at least three screws.



- Make sure the screws are fastened correctly and that the correct torque is applied on each screw.
- Make sure the screws are dimensioned to carry the weight of the tool plus the max load.
- When fastening EasySqueeze arms, use four screws (type M8) per arm.

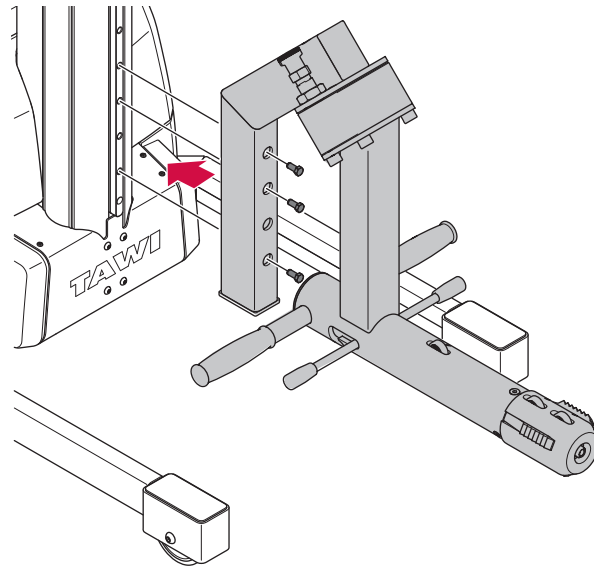

Torques to apply

Tool attachment for model	Type	Torque (Nm, class 8.8) (ft/lb)
PRO 40 and PRO80	M6	10 Nm (7.3 ft/lb)
PRO140 and PRO180	M8	24 Nm (17.7 ft/lb)
PRO250	M10	47 Nm (34.6 ft/lb)

Lift the lifter

To transport the lifter by lifting it, fasten a sling in the handle according to illustration and lift.

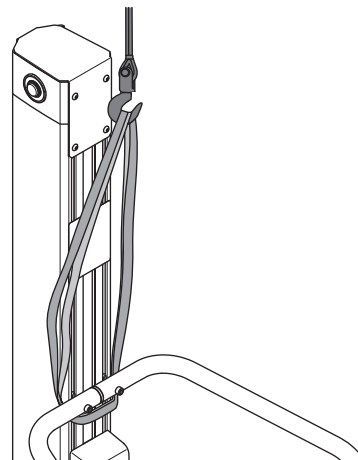

5 User instructions

This chapter describes how to operate the TAWI Lifting Trolleys.

Start the lifter

Make sure that the wheels rotate smoothly, that the brakes on the rear wheels are functioning properly and that the battery is charged. Review and perform relevant inspections. See *Daily inspections by operator on page 30*, *Quarterly inspections by inhouse maintenance on page 31* and *Yearly inspections by TAWI authorised service technician on page 31*.

1. Press the main switch to turn the power on.
 - » Response: The battery status display flashes for approximately three seconds and is thereafter lit.
2. The lifter is now ready for use.



- The lifter can be stopped at any time by pressing the emergency stop on the control panel.
- Only run the lifter when it is completely assembled.



- Check the lifter for safe functionality prior to each use, for instructions, see *Inspections on page 30*.
- The lifter has overload protection which will prevent tools from being raised when the specified max load is exceeded. If the overload protection is activated, reduce the load and try again.

Charge the battery

The battery can be charged with the battery pack attached or detached from the lifter. The battery can not be overcharged or charged too often. It is recommended to charge the battery as soon as it is not in use.



- A damaged power cord could cause electrical shock.
- Never touch any parts inside the battery pack when charging. Touching electrical parts can cause an electric shock.



- The lifter can be switched on or off when charging the battery. It is recommended that the lifter is switched off.
- To make sure not to damage the cord when pulling it out of the electrical outlet - grab, and apply the force to the plug.
- It is recommended to charge the battery in a full cycle, however the battery system can be plugged in for a longer period, since it cannot be overcharged. See *Battery charging indicator on page 19*.
- Never operate the lifter when the battery is charging (plugged in).
- The battery system has to be charged in a grounded electrical outlet.
- Charge the battery in a designated dry area.
- Normal charging of the battery creates very small amounts of hydrogen. However, the casing is ventilated, and thereby the risk of hydrogen collection is minimal.

Charge with battery pack attached

1. Connect the power cord to a grounded electrical outlet (100 - 240 V, 50 - 60 Hz).
2. When the battery is charged, pull the power cord out of the electric outlet and fasten it in its holder on the mast.

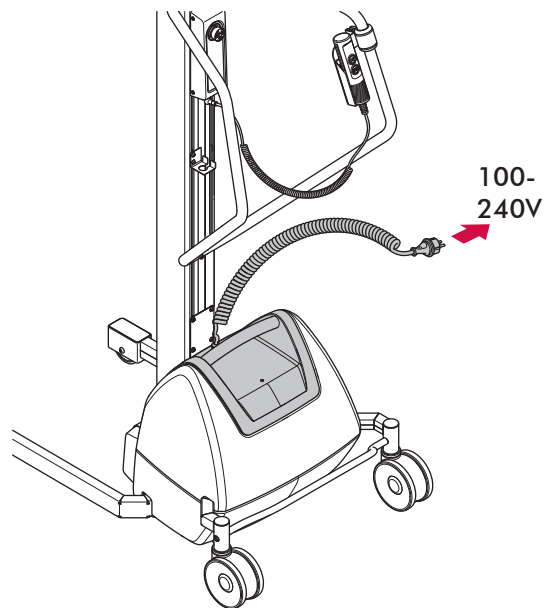

Charge with battery pack detached

1. Grab the battery pack handle and lift vertically to detach it from the lifter.
2. Place the battery in a designated dry area for charging.
3. Connect the power cord to a grounded electrical outlet (100 - 240 V, 50 - 60 Hz).
4. When the battery is charged, pull the power cord out of the electric outlet.
5. Place the battery back into position.
6. Fasten the power cord in its holder on the mast.

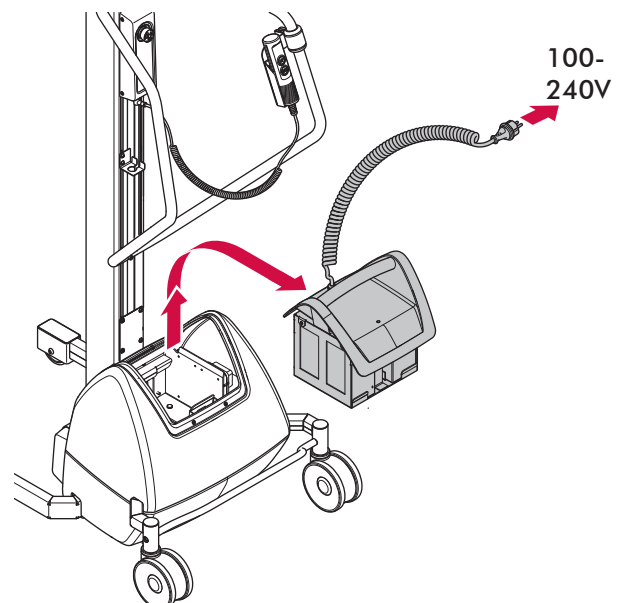

Battery charging indicator

The colour of the battery charging indicator communicates the following information:

PRO40 and PRO80

Orange	Boost charge
Yellow	Top up charge
Green	Ready/standby

PRO140, PRO180, PRO250, PRO100ESE and PRO200ESE

Yellow (steady)	Boost charge
Yellow (flashing)	Top up charge
Green	Ready/standby
Red	Error

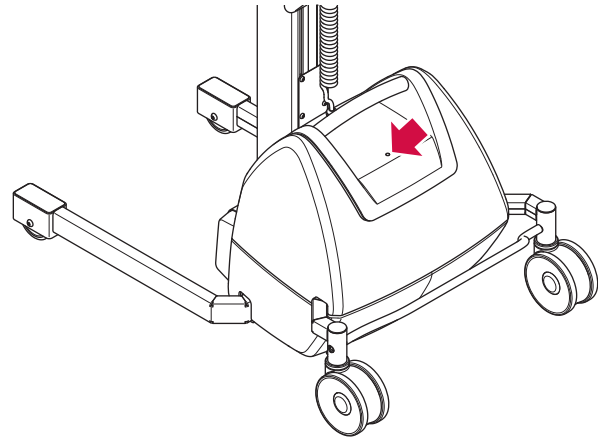

Move the lifter

Grab the handles and push the lifter to move it forward.



Always move the lifter with the load in a lowered position.

Apply brakes to the lifter

There are two different brake options depending on the model of the lifter; rear wheels separately braked or central brake.

Rear wheels separately braked (PRO40)

Engage or disengage the brakes on both rear wheels.

- A. Neutral
- B. Brake

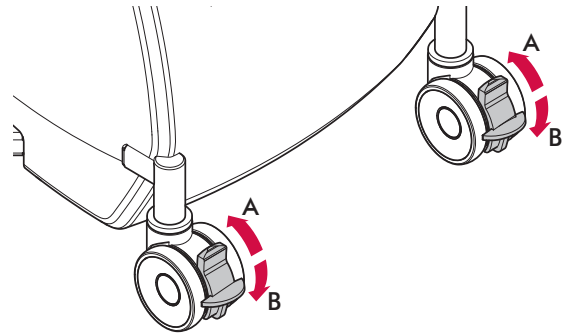

Central brake (all models except PRO40)

The central brake has three positions; brake, re-lease, and directional lock. Directional lock means that the rear wheels are locked in a fixed position, only allowing the lifter to move straight forward and straight backwards. This feature keeps the lifter steady and is helpful when it is transported a relatively long distance.

- A. Directional lock
- B. Neutral
- C. Brake

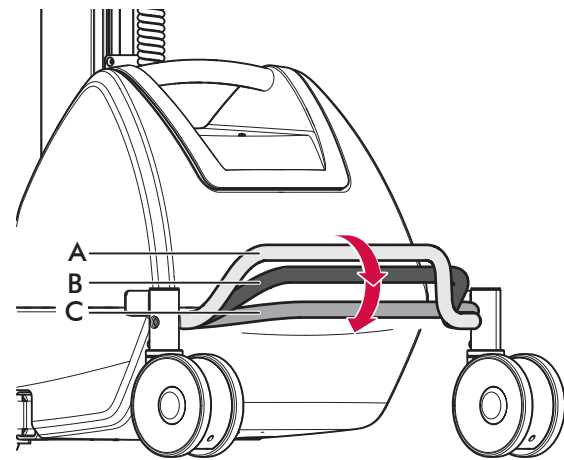

Always apply brakes when loading and unloading.

Adjust legs

This section only applies to PRO80 and PRO140. The legs of these models can be adjusted in width.



Always apply brakes and take out the battery pack before leaning the lifter. Also make sure that no cables are in the way or squeezed between the operator handle and the floor.

1. Lean the lifter and place it on its back.
2. Adjust the legs one side at a time:
 - a. Loosen and remove the screw closest to the mast.
 - b. Loosen, but do not remove, the other screw (located farthest away from the mast).
 - c. Refit the removed screw into the middle position to enable the leg to move inwards and outwards.
 - d. Extend the leg to desired position, make sure it ends up within the max and min markings.
 - e. Remove the screw from the middle position.
 - f. Put the screw back and fasten into its original position.
 - g. Make sure both screws are tightened to 24Nm (17.7 ft/lb).
3. Repeat step (2) for the other leg.

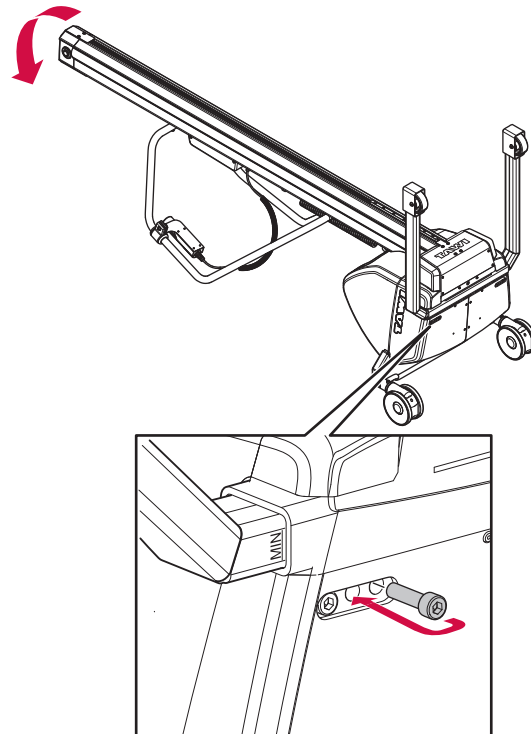

- Always adjust the legs within the max and min markings.
- Exceeding this may cause damage to the lifter and may cause injuries.



- The legs do not have to be adjusted symmetrically.
- Each leg is adjustable by 150mm (5.9in).

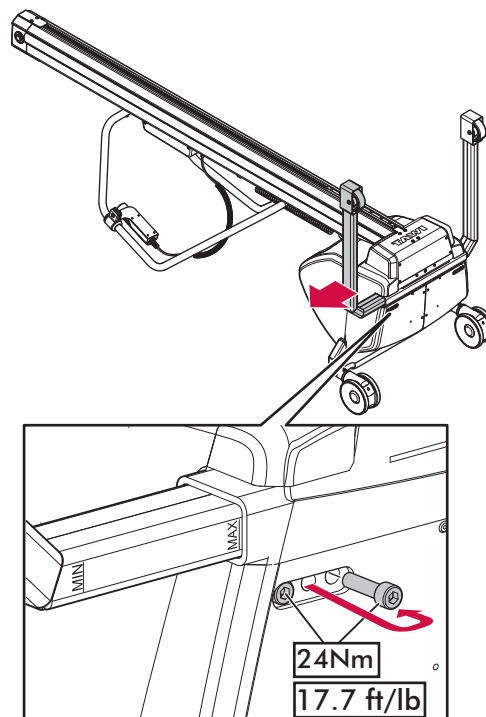

Operating tools

Tools are handled using a detachable hand control and the control panel. If the lifter is not equipped with a hand control, only the control panel is used.



If a tool hits an object or surface during lowering, a safety mechanism will stop the downwards movement. This is to prevent accidents.

Raise and lower with the hand control

The hand control can be detached from the handle and has two buttons, up and down. The hand control is equipped with two speeds. Press firmly for faster movement and press lightly for slower movement.

Standard hand control

- A. Press UP to raise
- B. Press DOWN to lower

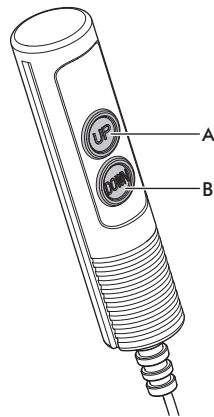

The Position stop hand control has a button on top, see *Position stop* on page 29.

- A. Press UP to raise
- B. Press DOWN to lower
- C. Press the top button on top to activate Position stop.

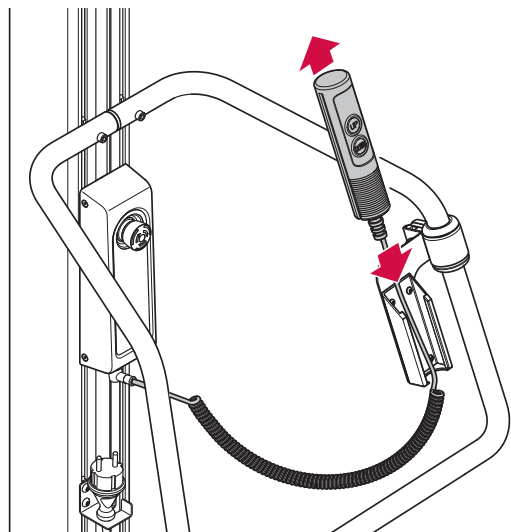
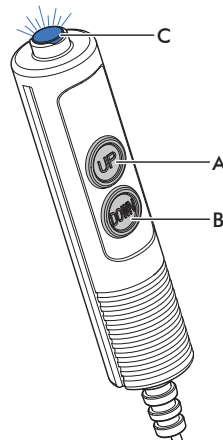

Control panel

There are three standard configurations of the control panel, they depend on the model of the lifter.

Control panel on lifter equipped with a hand control.

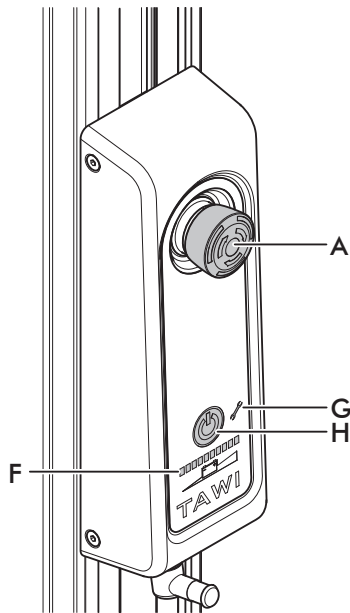

Control panel on lifter NOT equipped with a hand control.

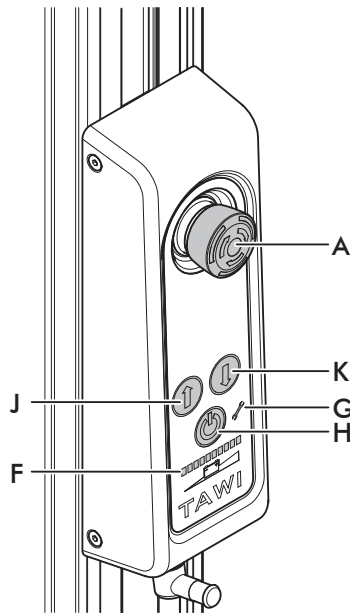

Control panel on lifter equipped with EasySqueeze.

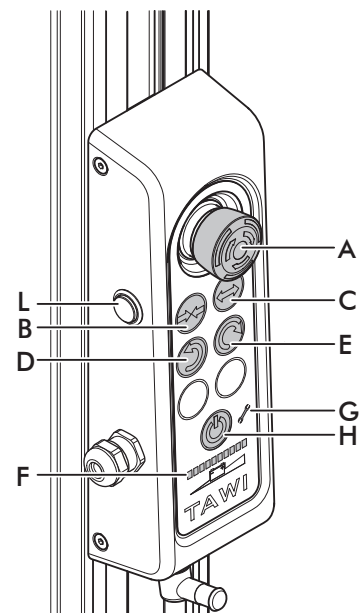

- A. Emergency stop
- B. Close squeeze arms
- C. Open squeeze arms
- D. Rotate counterclockwise
- E. Rotate clockwise
- F. Battery status display
- G. Service indicator
- H. Main switch
- J. Raise the tool (one speed)
- K. Lower the tool (one speed)
- L. Safety button

Battery status display

The battery status is indicated by the number of lit bars in the battery status display. When the bars are flashing, the number of flashing bars communicate messages, see *Codes on the battery status display* on page 35.

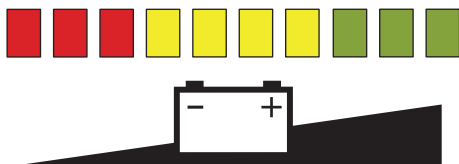

General tools

General tools includes platforms, fork tools etcetera, see *Tools on page 36* for additional examples. These can be used to raise and lower loads and objects using the hand control and/or the control panel.



- Make sure that the load is stable and is secured on the general tool.
- Make sure the general tool is loaded according to load diagrams, see *Loading on page 14*.
- Always transport a load in a lowered position.

EasySqueeze

The EasySqueeze is an electrical gripping tool that handles objects from their outer surfaces. The EasySqueeze is operated from the control panel, see *Control panel on page 23* for illustrations of the buttons to use.



- Always stay clear of the area under the tool.
- Do not stand between the grippers.



Apply brakes when loading and unloading.

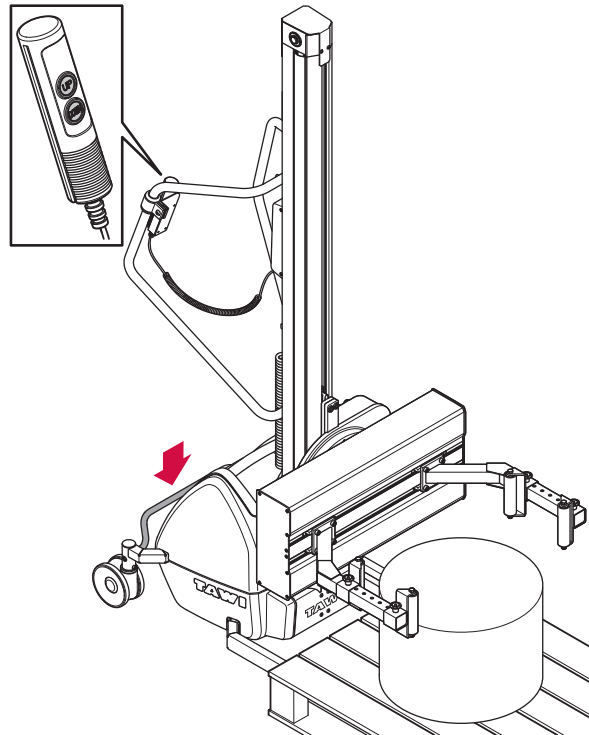

Grip an object

1. Move the lifter and use the hand control to place the EasySqueeze arms centred in height and depth over the object that is to be moved.
2. Press the *Close squeeze arms (B)* button and keep it pressed.
 - » Response: When the preset gripping force is reached, the EasySqueeze arms stop and the *Close squeeze arms (B)* button is lit green.



Make sure all grippers are pressed against the surface of the object. If they are not, loosen the EasySqueeze arms and repeat step 2.

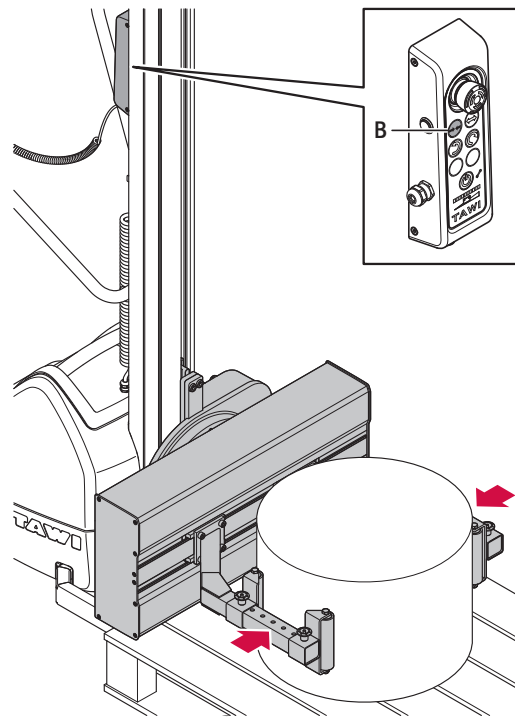

Rotate an object

When an object is gripped with the EasySqueeze and raised approximately 20cm (7.8in), it is possible to rotate the object clockwise or counterclockwise.

1. Press and hold the *Rotate counterclockwise (D)* button or the *Rotate clockwise (E)* button.
2. Release the button when the desired or pre-defined angle is reached.
 - » Response: When the button is released, the rotation stops.

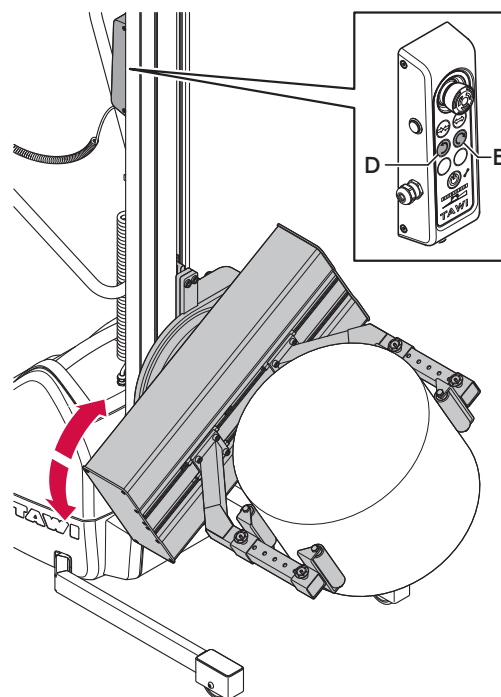

Transport an object



Transport the object at a lowered position (in this case, approximately 20cm (7.8in) above ground level).



It is desirable to transport the object in an angle where it is resting on one of the EasySqueeze arms.

1. Raise the object approximately 20cm (7.8in) above ground level.
2. Release the brake.
3. Grab the handle and push the lifter to desired location.

Release an object



- Make sure there is enough space when unloading so that the EasySqueeze arms do not collide with any surrounding items when moving outwards to release the object.
- Do not release an object during raising or lowering.

1. Apply the brake.
2. If applicable, rotate the object to the desired angle for unloading.
3. Use the hand control to raise the object to desired height for unloading.



Make sure that the object is placed in the correct position and that it is safe to release it.

4. Press the *Open squeeze arms (C)* button and the *Safety button (L)* simultaneously and keep the buttons pressed to release the object.

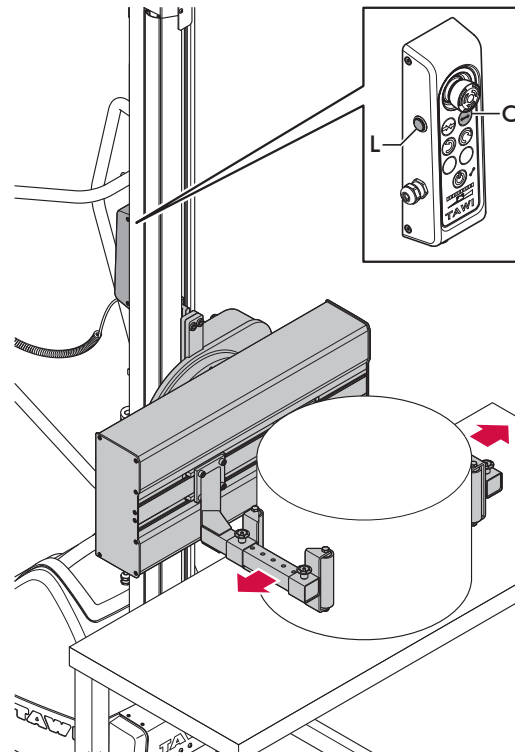

Coregripper

The Coregripper is a reel handling tool that handles the reel from the core. It is designed to handle reels with a cardboard core. See *Control panel on page 23* for illustrations of the buttons to use when operating an electrical Coregripper.

Pick up and rotate a reel



Always stay clear of the area under the reel.



- The Coregripper is mainly designed to pick up reels with the core in a vertical position.
- When lifting reels with the core in horizontal position, the reel can fall off the Coregripper. Make sure there is a secure grip before rotating.

1. Move the lifter and place the centre of the Coregripper above the core of the reel.



Apply brake to the rear wheels.

2. Press and hold the Down button on the hand control to lower the Coregripper into the core of the reel.
3. Release the Down button when the Coregripper has reached desired depth.
4. Activate the gripping jaws by lifting the extractor handle out of its slots. Use both hands.
5. Press and hold the Up button on the hand control to lift the reel.
6. Raise the reel approximately 20cm (7.8in) from ground level to check that the core is gripped safely.



Make sure nobody is close to the lifter when preparing to rotate the reel.

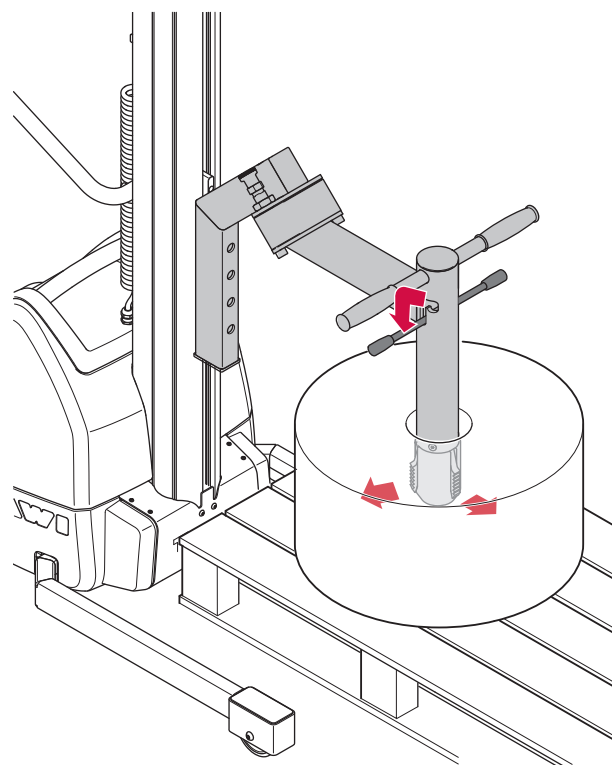
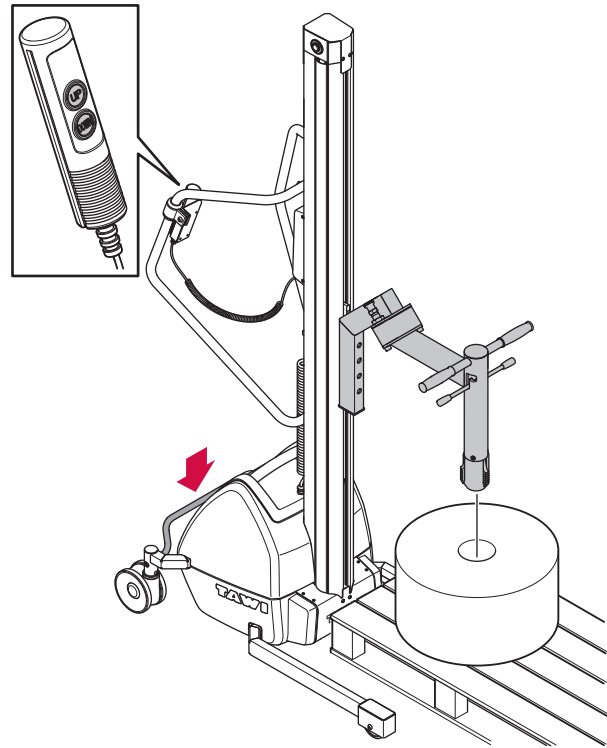

7. Rotate the Coregripper to horizontal position by grabbing the OPPOSITE side of the handle from the side you stand with reference to the mast.
8. Pull the rotation lock pin outwards and hold.
9. Pull the handle to rotate the reel.
10. Carry the rotation through before putting the rotation lock pin back gently.



For an effortless rotation, try to place the reel so that its center of gravity ends up on the axis of rotation.

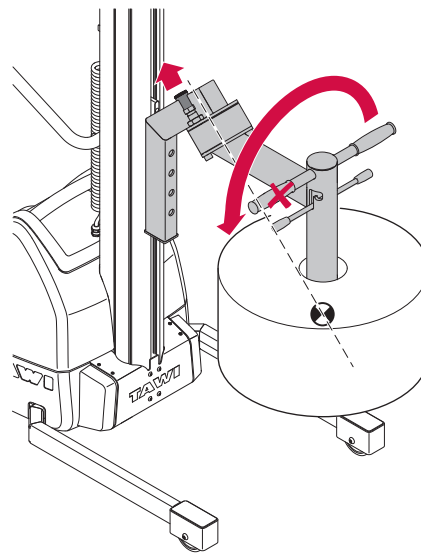

Transport a reel

1. Release the brake and push the lifter to desired location



- Always transport the reel with the core in horizontal position.
- Always transport objects at a lowered position.

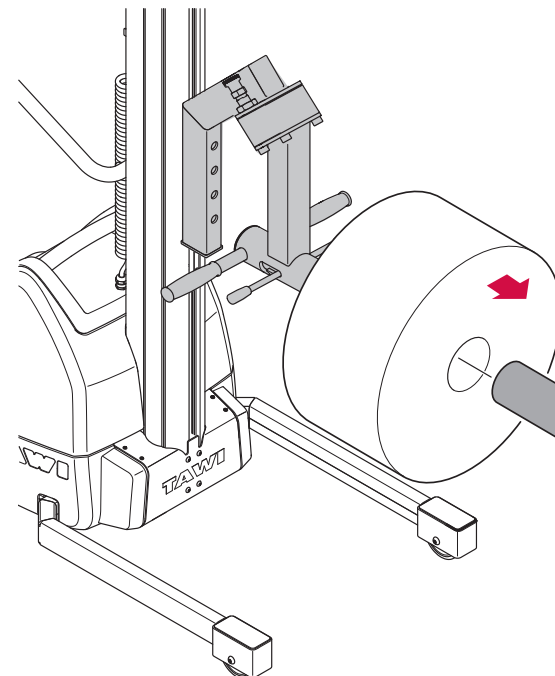

Release a reel onto a shaft

1. Push the lifter and raise the Coregripper to desired height (until it is in line with the shaft).



Make sure brakes are applied to the rear wheels when handling the reel.

2. Disengage the gripping jaws by putting the extractor handle back in its slots.
3. Manually push the reel onto the shaft.

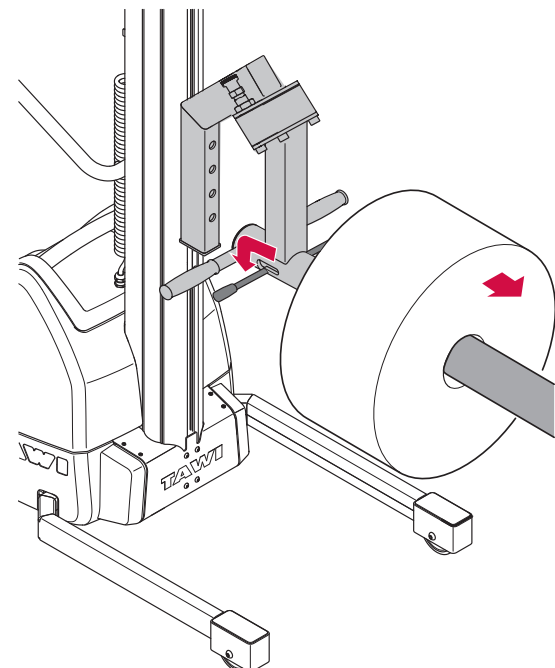

Position stop

A Position stop switch can be assembled on the mast between the top and bottom position switches. The Position stop can also be assembled at delivery



- There is always one top limit switch and one bottom limit switch assembled on the lifter. Make sure the Position stop switch is placed between the top and bottom limit switches.
- NEVER move the top or bottom limit switches.



The Position stop is configured to stop the tool when the tool moves upwards or downwards. Contact a TAWI authorised service technician for support with configuration of the Position stop.

1. The Position stop hand control has a button on top.
2. Press the top button (C) to activate the Position stop.
 - » Response: The top button (C) is activated and lit.
3. Depending on how the Position stop is configured, press UP (A) or DOWN (B) to move the tool to desired position.
4. The tool stops when reaching the Position stop.
 - » Response: The tool stops.
5. Press the top button (C) to move the tool past the position switch.
 - » Response: The top button (C) stops being lit.

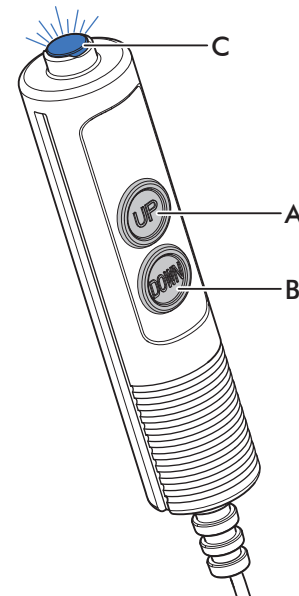

Ladder

TAWI Lifting Trolleys have a ladder accessory which can be used to facilitate work. Be careful when using the ladder accessory along with the lifter, and pay attention to the sticker on the ladder, see *Label on TAWI Lifting Trolley ladder on page 10*.



When using a ladder there is a risk of slipping and falling off it. Be careful and make sure:

- To have a good grasp of a supporting object when stepping onto and climbing the ladder.
- To have clean shoes with a good grip.
- That the ladder is clean and provides a good grip for your feet.
- Do not exceed the max load of the ladder, see *Label on TAWI Lifting Trolley ladder on page 10*.
- The brake must be applied on the lifter when using the ladder.

6 Service & maintenance

This chapter provides information about service and maintenance of the lifters. The chapter is divided into three sections based on who is to perform the inspections and how often the inspections are to be carried out. Daily by the operator, quarterly by inhouse maintenance or yearly by TAWI authorised service technician.

For technical service, maintenance or repairs contact your TAWI representative or info@tawi.com. TAWI must authorise all modifications to this product. TAWI assumes no responsibility for unauthorised modifications and guarantees will automatically become invalid if unauthorised modifications have been made.



- Service must be carried out on a yearly basis or when the service indicator lamp (see *G. Service indicator on page 23*) on the control panel is lit.
- If any damage/wear is detected on the lifter, this must immediately be reported to TAWI or authorised TAWI representative. The lifter must be taken out of commission and not be used until the damage has been repaired.
- All service must be carried out with the battery disconnected. The battery pack can be lifted out in order to remove the power source.
- In order to deal with the lifter's cables and wiring, a good knowledge of electricity and TAWI electrical schedules of the lifters is required.



- If the battery needs to be replaced, either order a new battery pack from TAWI or make sure that an original battery is used. If assistance is needed, contact TAWI.
- Keep the lifter clean, use a damp cloth. Do not use chemical cleaners.

Inspections

The following inspections are to be carried out.

Daily inspections by operator

1. If yearly service has been carried out, make sure that the service inspection date is valid.
2. Check that the max lifting capacity signs are visible.
3. Check that warning and operating labels are visible.
4. Make sure wheels and bearings are functioning and running smoothly.
5. Make sure breaks are functioning correctly and check for signs of damage/wear.
6. Check external wiring for damage/wear.
7. Make sure that the hand control is functioning properly.

Continue on the next page

8. Make sure correct and safe gripping of loads with EasySqueeze is achieved; The close button (A) on the control panel will be lit green when the correct gripping force is achieved.
9. Check that the switch for deactivating rotation on the EasySqueeze is functioning correctly by lowering the EasySqueeze tool to the min position and try to rotate. The turn function should be deactivated if the switch is working correctly.
10. Make sure that the emergency stop is working correctly.
11. Lower the tool (without load) until it hits a surface or object close to the ground to check that the tipping safety function is working properly.

Quarterly inspections by inhouse maintenance

1. Double check (carry out) all daily inspections mentioned in *Daily inspections by operator*.
2. Check all screws and nuts for damage/wear.

Yearly inspections by TAWI authorised service technician

1. Check that CE mark and serial number on the identification plate are visible.
 2. Make sure all screws and nuts are tightened according to *Torques to apply on page 16*.
- 
3. Pay extra attention to screws and nuts on mast, legs, tool attachments and EasySqueeze arms.
 4. Make sure the tool is correctly attached and fastened securely.
 5. Check belt wheels for signs of damage/wear.
 6. Check the belt for wear and tear and make sure that it is properly secured in belt lock.
 7. Make sure that upper and lower switches are functioning correctly.
 8. Control that the battery voltage level is sufficient.
 9. Control that the charger is supplying correct voltage.
 10. Check all wiring for signs of damage/wear and make sure all connections are correct.
 11. Make sure that overload protection is functioning properly by test lifting with 10% overload according to indicated max load capacity.
 12. Control screws and safety functions on tools e.g. springpins, safety locks etc.
 13. Check belt tension and tighten belt if needed.
 14. Control welds for damage/wear on legs and tools caused by misuse, overload etc.
 15. Reset service indicator when inspection service has been carried out.

Torques

Type	Torque (Nm, class 8.8) (ft/lb)
M5	6 Nm (4.4 ft/lb)
M6	10 Nm (7.3 ft/lb)
M8	24 Nm (17.7 ft/lb)
M10	47 Nm (34.6 ft/lb)

7 Troubleshoot

This chapter provides information on how to investigate or rectify problems that may occur. Actions marked with (*) must be carried out by TAWI or a TAWI authorised service technician.

Main unit

Problem	Likely caused by	Action required
Tool does not move up or down	Main switch is turned off.	→ Turn main switch on.
	Emergency stop is engaged.	→ Disengage the emergency stop.
	Batteries need charging.	→ Charge batteries according to manual. See (A) on page 35.
	Batteries are drained.	→ Change batteries.* See (A) on page 35.
	Charger is damaged.	→ Check if charger supplies correct voltage, if not replace charger.* See (A) on page 35.
	Overload protection is activated.	→ Reduce load to max stated capacity.
	Limit switches are broken/damaged.	→ Check functions of limit switches, replace if needed.*
	No signal from hand control.	→ Check if the hand control or connection cable are damaged. Replace if necessary.
	No signal from control panel.	→ Check signal from the control panel to circuit board.* See (H) on page 35.
	Wires or connections are loose in battery pack.	→ Check wire connection on batteries. Connect if necessary.
	Fuse has tripped.	→ Check fuse, replace if broken.
	Mother board is damaged.	→ Replace mother board.*
	Control board is damaged.	→ Replace the control panel.*
	Circuit board damaged.	→ Replace circuit board.*
Tool moves slowly up/down	Batteries are weak.	→ Charge batteries according to manual.
	Excessive friction in sleigh.	→ Check if sleigh moves smoothly upwards with manual force, if jammed, contact a TAWI authorised service technician.*
The belt slams at descent	Belt needs tension.	→ Tighten the belt.*

Problem	Likely caused by	Action required
Noise from belt drive	Belt transmission is worn in an inappropriate way.	→ Check belt and belt wheels for wear, replace if needed.*
Brake does not work	Brake has been misused.	→ Replace rear wheels.
Battery status display is not lit	Wires or connections are loose.	→ Check wires and connections between mother board and control panel.
	Control panel is damaged.	→ Replace control panel.*
	Emergency stop is activated.	→ Deactivate emergency stop.
Charge indicator is not lit	LED has come loose from position.	→ Check if LED has come loose. Fasten or replace if necessary.
	Charger is broken.	→ Replace battery charger.*

Tools

Problem	Likely caused by	Action required
EasySqueeze arms do not move	Any faults of main unit.	→ Check if main unit is working properly.
	Overload protection is activated.	→ Release pressure from ES arms, make sure lifted object is in secure position before releasing pressure.
	Actuators are damaged.	→ Replace actuators.*
	No electrical connection in slip ring.	→ Check connection in slip ring, replace if needed.*
	No signal from control panel.	→ Check signal from control panel to circuit board.*
	Mother board is damaged.	→ Replace mother board.*
	Control board is damaged.	→ Replace control panel.*
	Circuit board for squeeze function damaged.	→ Replace circuit board.*
EasyTurn does not turn	Any faults of main unit.	→ Check if main unit is working properly.
	Overload protection is activated.	→ Place center of gravity of load in rotation center.
	Turn motor is damaged.	→ Replace turn motor.*
	No signal from control panel.	→ Check signal from control panel to circuit board.*
	Mother board is damaged.	→ Replace mother board.*
	Control board is damaged.	→ Replace control panel.*
	Circuit board for turn function is damaged.	→ Replace circuit board.*
EasyTurn does not stop at pre-defined angle	Angle sensor broken.	→ Replace angle sensor.*
	No signal from control panel.	→ Check signal from control panel to circuit board.*
	Circuit board for turn function is damaged.	→ Replace circuit board.*

Codes on the battery status display

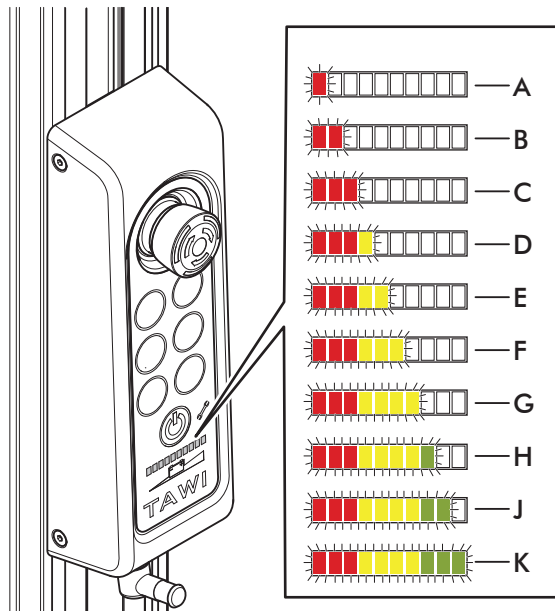

Message	Action required
A. The battery needs charging.	→ The lifter is shut down and needs charging. Switch it back on and lower the tool to a safe level. Charge immediately.
B. There is a bad connection to the motor.	→ Check all connections.
C. The motor has a short circuit to a battery connection.	→ Contact a TAWI authorised service technician.
D. N/A	
E. N/A	
F. Sleepmode (follows a preset period of inactivity, the function is there to save the battery).	→ Restart the lifter.
G. Throttle fault.	→ Make sure the throttle is in rest position before the lifter is started.
H. Controller fault.	→ Make sure all controller connections are secure.
J. N/A	
K. An excessive voltage has been applied to the control.	→ Often caused by a poor battery connection. Check the battery connections.

8 Tools and accessories

This chapter presents a selection of tools and accessories designed for TAWI Lifting Trolleys.

Tools

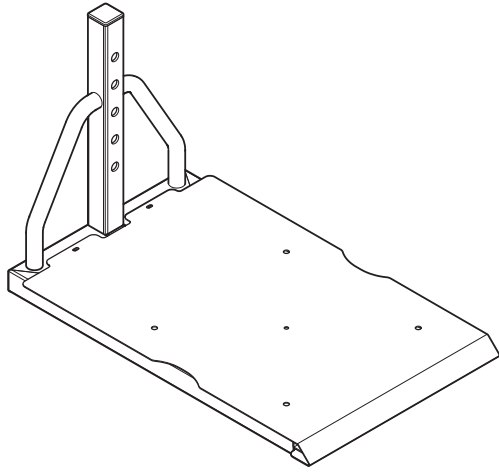

Platform 600x400mm (23.6x15.7in) (LxW)

Suitable for PRO80, PRO140, PRO180 and PRO250.

Two surface materials: stainless steel and checker plate.

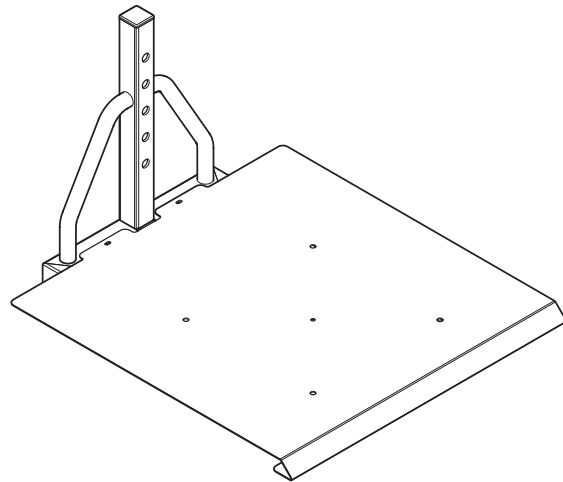

Platform 600x600mm (23.6x23.6in) (LxW)

Suitable for PRO80, PRO140, PRO180 and PRO250.

Surfaces materials: stainless steel and checker plate.

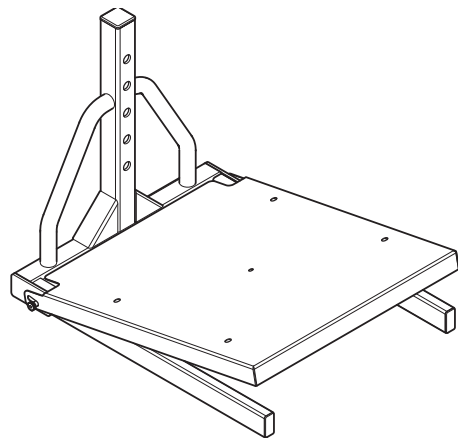

Fold up platform 500x440mm (19.6x17.3in) (LxW)

Suitable for PRO80, PRO140 and PRO180.

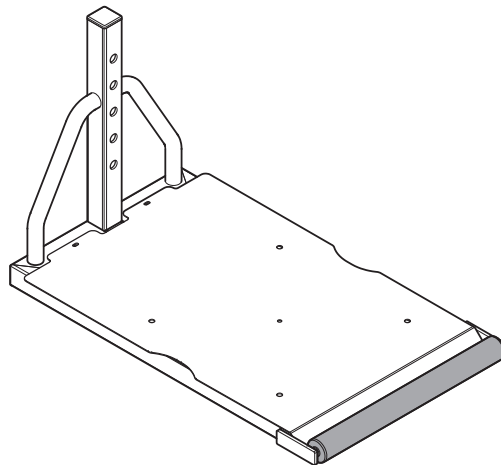

Loading roller

Suitable for all platforms except the fold up platforms.

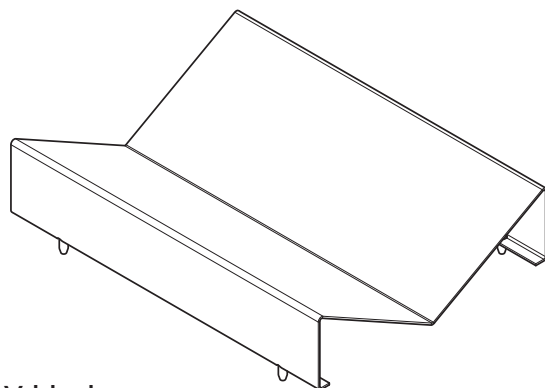

V-block

Suitable for all platforms.

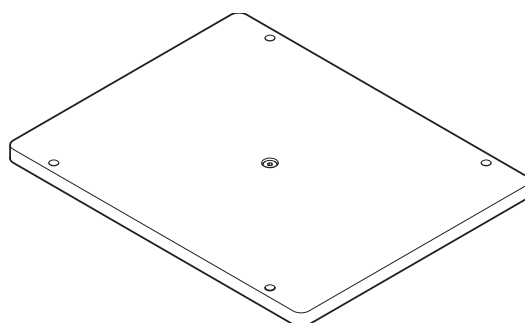

Rotating plate for V-block

Suitable for all platforms with stainless steel surface.

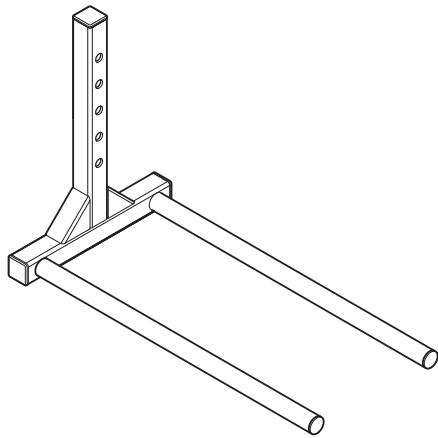

Tube fork L=600mm (L=23.6in)
 Suitable for PRO80, PRO140 and PRO180.

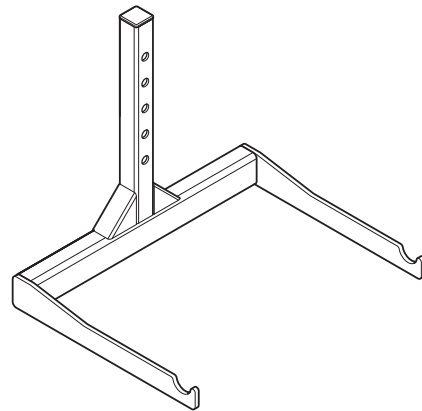

Fork for shafts
 Suitable for PRO80, PRO140, PRO180 and PRO250

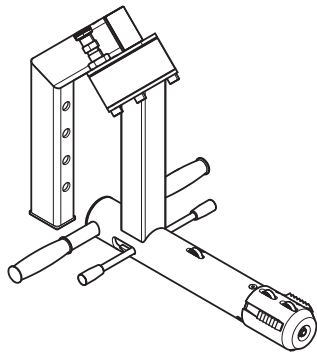

Coregripper Ø76
 Suitable for PRO80, PRO140 and PRO180.

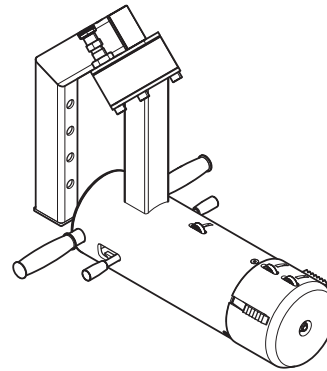

Coregripper Ø152
 Suitable for PRO80, PRO140 and PRO180.

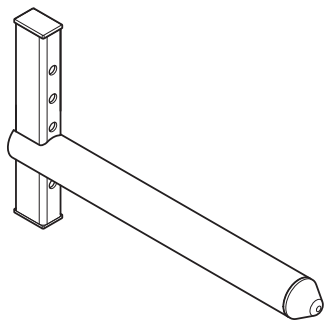

Boom L=500mm (L=19.6in)
 Suitable for all models.
Boom L=1000mm (L=39.3)
 Suitable for all models except PRO40.

Accessories

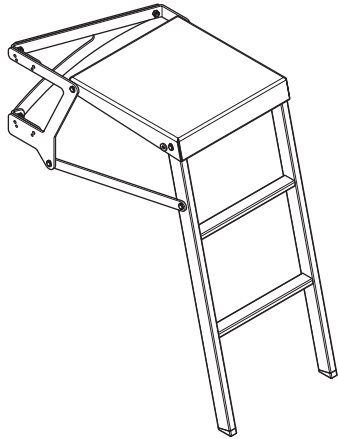

Ladder

Suitable for PRO40, PRO80, PRO140, PRO180 and PRO100ESE.

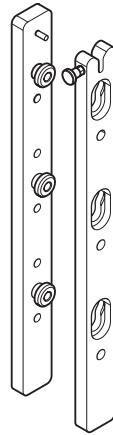

Quick coupling

Suitable for all models.

Appendix I

Load test certificate.

TAWI

Load test certificate

This certificate covers:

- Standard lifters or
- Derivative lifters with special tools

It is reproduced from the master TYPE certificate produced by the manufacturers and specified below.

Product: Protema lifter

Certificate type: 17-SKM-CM-0100

Manufacturer: TAWI AB, BOX 10205, 434 23 KUNGSBACKA, SWEDEN

Type of tool/special project:

Serial number:

The product is tested according to Machine Directive 2006/42/EG with Safe Working Load (SWL):

SWL:

I certify on behalf of the above company that the above item is fit for the purpose at SWL specified above:

Date:

Signature:

Appendix II

Inspection record. Keep the last page empty for copying in case records run out.

TAWI

Inspection record

Update the inspection record after each yearly inspection.

Date:	Stamp of approval
Signed:	
Next inspection date:	

Date:	Stamp of approval
Signed:	
Next inspection date:	

Date:	Stamp of approval
Signed:	
Next inspection date:	

Date:	Stamp of approval
Signed:	
Next inspection date:	

Date:	Stamp of approval
Signed:	
Next inspection date:	

Inspection record

Update the inspection record after each yearly inspection.

Date:	Stamp of approval
Signed:	
Next inspection date:	

Date:	Stamp of approval
Signed:	
Next inspection date:	

Date:	Stamp of approval
Signed:	
Next inspection date:	

Date:	Stamp of approval
Signed:	
Next inspection date:	

Date:	Stamp of approval
Signed:	
Next inspection date:	

Date:	Stamp of approval
Signed:	
Next inspection date:	

Inspection record

Update the inspection record after each yearly inspection.

Date:	Stamp of approval
Signed:	
Date for next service:	

Date:	Stamp of approval
Signed:	
Next inspection date:	

Date:	Stamp of approval
Signed:	
Next inspection date:	

Date:	Stamp of approval
Signed:	
Next inspection date:	

Date:	Stamp of approval
Signed:	
Next inspection date:	

Date:	Stamp of approval
Signed:	
Next inspection date:	

Inspection record

Update the inspection record after each yearly inspection.

Date:	Stamp of approval
Signed:	
Next inspection date:	

Date:	Stamp of approval
Signed:	
Next inspection date:	

Date:	Stamp of approval
Signed:	
Next inspection date:	

Date:	Stamp of approval
Signed:	
Next inspection date:	

Date:	Stamp of approval
Signed:	
Next inspection date:	

Date:	Stamp of approval
Signed:	
Next inspection date:	

TAWI AB

Box 102 05

Transportgatan 1

434 23 Kungsbacka

Tel: +46 (0) 300 -185 00

Fax: +46 (0) 300 189 90

info@tawi.se

Revision 1.2