



User friendly control panel

- emergency stop
- service indicator
- battery status display

SmartPack

Easily switch the battery pack to extend runtime through multiple shifts.



- Flexible solution for lifting and transporting everything from reels to boxes in an ergonomic and efficient manner.
- The lifter is available in stainless steel, equipped with a white FDA approved cover, ideal for food manufacturing and pharmaceutical industry
- SafeDrive ensures that if a tool hits an object during lowering, it will stop immediately.
- The lifter is belt driven, resulting in safe, quiet and smooth oil free drive.
- With our wide selection of tools and accessories, the PRO40 can be optimized for your needs. Standard tools and accessories are presented on the following pages.

Contact your sales representative for bespoke solutions.

[Call us!](#)

Technical specifications

Description	Specifications
Article No PRO40M / PRO40MSS	89110 / 89115
Lifting capacity	40 kg / 88 lbs
Stroke	1040 mm
Weight of unit	41kg
Total height of unit	1640 mm
Battery charger	100-240V, grounded 50-60 Hz
Battery	2x12V 7Ah
Watt	40 W
Lifts per charge	40 kg x 1m x 100 times
Up and down motions	Control panel (one speed)
Front wheels	Swiveling
Brake system	Rear wheels separately braked
Overload protection	Incorporated in circuit load
IP-rating	IP24
Lifting speed	0,1 m/s

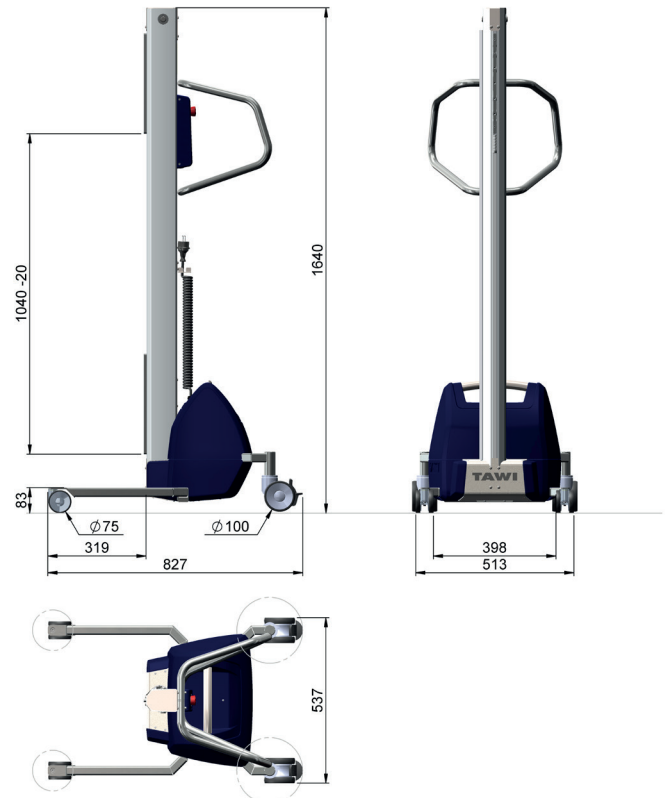

Load diagram

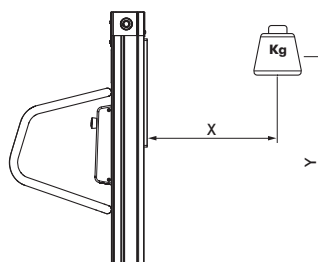
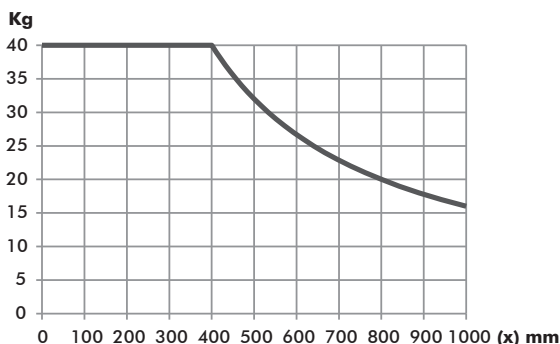

All measures are LxWxH

Platform

Safely lift and transport goods of varying sizes with this robust platform mounted on your PRO40.

Art. 891610 ss surface, 450x360 mm

The platform can be mounted ± 100 mm from position in drawing.

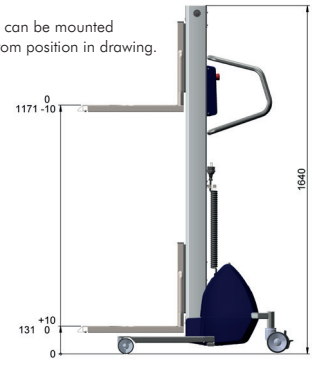

A2 = Stainless steel
FZB = Zincified mild steel

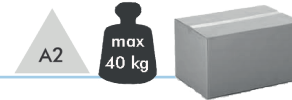

Fold up platform

This fork tool with a foldable stainless steel platform lets you lift boxes and crates with the same tool.

Art. 892634
Surface size 500x450 mm
Fork length 500 mm, ID 370 mm

The platform can be mounted ± 100 mm from position in drawing.

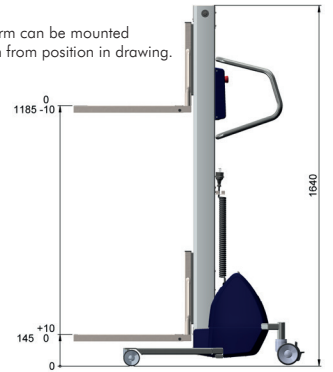

Boom

Lift and transport reels onto shafts and machines without effort with this ergonomic boom tool.

Art. 892620 $\text{\O}63,5 \times 500$ mm
Art. 892621 $\text{\O}63,5 \times 1000$ mm

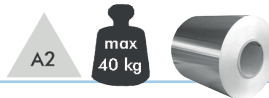
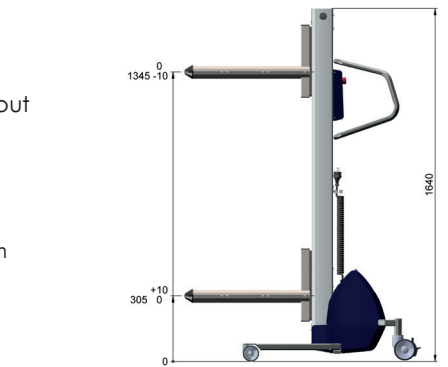

Roller boom

This boom is equipped with rollers for effortless loading and unloading of reels. The safety pin holds the reel in place and ensures safe transport. The pin is automatically released when the boom hits an object.

Art. 892622
Handles reels up to 600 mm

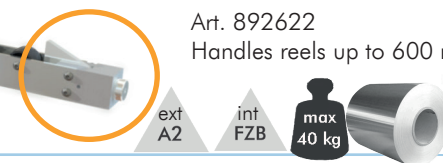
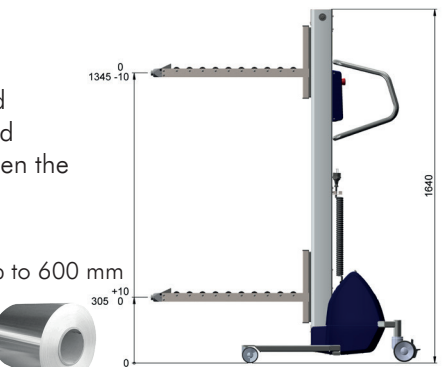

All measures are LxWxH

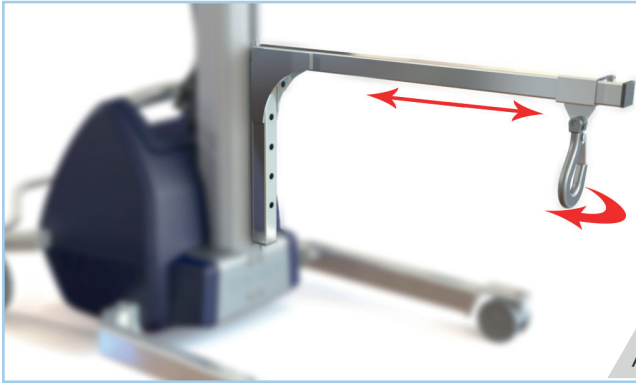

Crane arm with hook

A crane arm with an adjustable hook is ideal for reaching into narrow spaces, handling machine parts, small drums etc.

Art. 892623
Arm length 600 mm

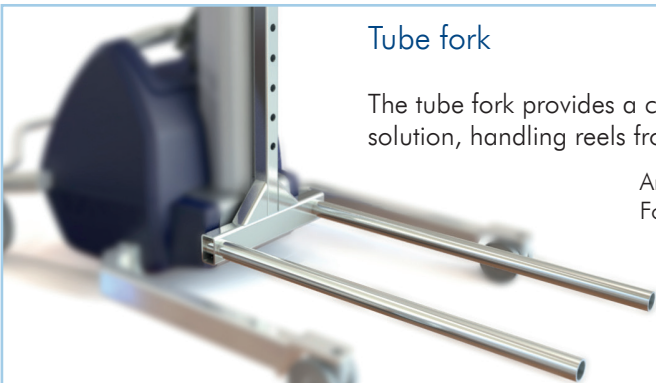
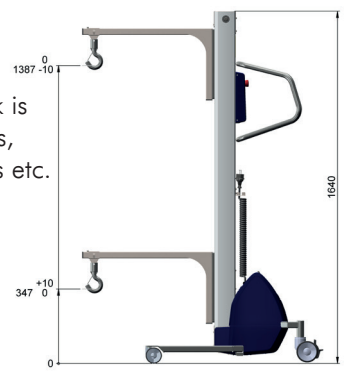

Tube fork

The tube fork provides a cost efficient reel handling solution, handling reels from their outer surface.

Art. 892631
Fork length 600 mm, C-C 250 mm



! The fork can be mounted
± 100 mm from position in drawing.

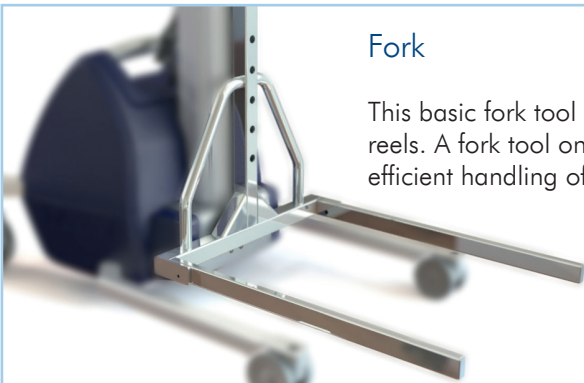
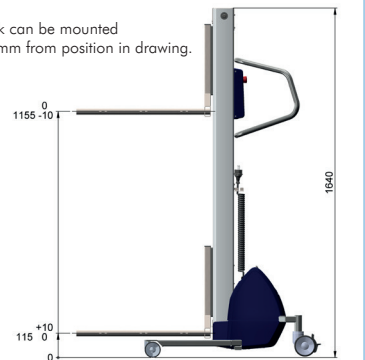

Fork

This basic fork tool is ideal for handling both crates and reels. A fork tool on your PRO80 allows for ergonomic and efficient handling of plastic crates.

Art. 892630
Fork length 500 mm, ID 370 mm

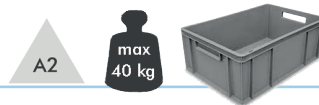

! The fork can be mounted
± 100 mm from position in drawing.

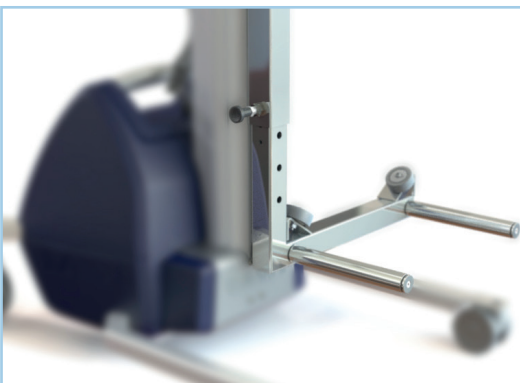
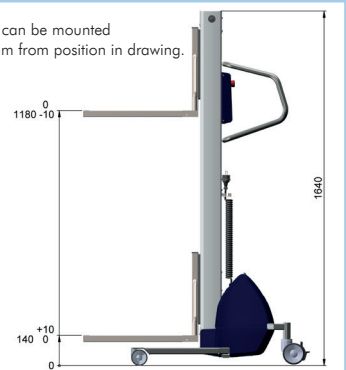

Tyre tool

Lift and transport tyres to where you need them with this specialized tool. Commonly used in testing facilities and assembly lines to install and remove tyres in an ergonomic and efficient manner.

Art. 892635

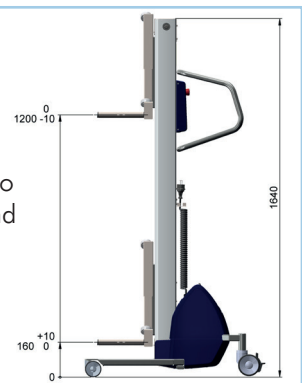

All measures are LxWxH

Ergonomic

Ladder

Fold-up ladder, optimal for pushing goods from the tool onto a shelf. This ergonomic three step ladder can be mounted on both sides of the lifter.

Art. 890692

FZB



QuickLoad

This feature for smooth and precise positioning of load saves valuable time and effort for the operator. Positioning is conveniently controlled with the detachable hand control.

Art. 891500



V-block with rotation plate

A v-block on your platform is a flexible and cost efficient solution for handling all types of reels. The rotation plate is suitable for all stainless steel platforms and enables effortless rotation of the v-block. The v-block can also be used without rotation plate.

Rotation plate Art. 890640

V-block Art. 890641, block length 380 mm, for reels up to Ø600 mm

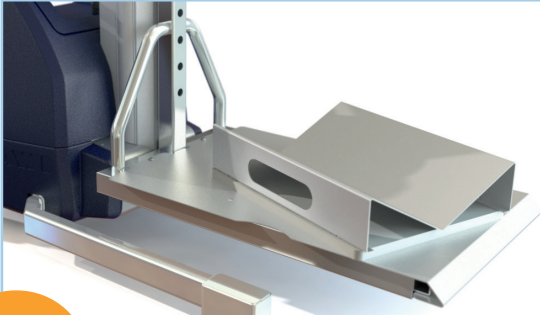

Efficient

Quick coupling

With a quick coupling, switching between different tools is quick and simple, for efficient handling of various goods.

Art. 892691, sleigh half
Art. 892692, tool half



SmartPack

Extend working hours with a detachable battery pack including charger.

Art. 891400



Articulating adapter

Enables easy articulation of tools, adding flexibility to your lifter. The adapter can be mounted between all types of tools.

Art. 892697

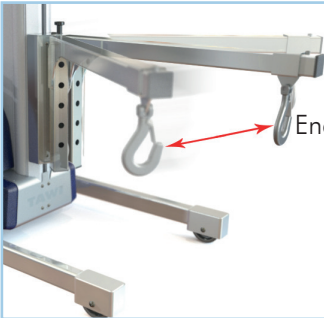

ESD wheels

Ensure safety with ESD wheels when electrostatic discharge is not allowed, e.g. in environments where electrical components are assembled.

Art. 890692

Safe



Roll kit for platform

Goods are safely rolled onto the lifter with a roll kit attached to the platform. Fits platform 891610.

Art. 890642 steel roll Ø40x360 mm
Art. 890643 plastic roll Ø40x360 mm

